

### Overview

The LC83010N, 83010NE is a single-chip digital signal processor (DSP). It is designed for use in the application fields such as a digital processing of audio signals.

The LC83010N, 83010NE CMOS processor has various on-chip filtering circuits such as a graphic equalizer for reproduction of sound quality. It also has simulation circuit for reverberation (sound reflection and echo), so that sound field with surround and delay can be created.

The LC83010N and LC83010NE are upgraded versions of the LC83010 and the LC83010E. The LC83010N and LC83010NE have a 64fs clock output that enables improved interfacing with external A/D converters. TEST5 has been renamed FS640/T5 and incorporates both the new clock output and the original test output.

### Features

- LSI functions

1) Dual Harvard Architecture: Enables simultaneous processing (multiply and addition) of stereo signals in a single instruction cycle.

The LC83010N, LC83010NE processor has the following two independent units:

- Multiplier : 24 bits x 16 bits (fixed-point decimal)
- ALU : 32-bit arithmetic calculation, 24-bit arithmetic and logical operations
- ACCumulator (ACC) : 32 bits
- Temporal Registers (TMP0 to TMP7) : 32-bit for each
- Internal Memory
 

Data RAM	128 x 24 bits
Coefficient RAM	256 x 16 bits
Constant ROM	256 x 24 bits

2) Program Memory Capacity (RAM) : 320 x 32 bits

3) A variety of I/O interfaces

- Audio signal I/O
  - 1 channel for input (applicable to various formats)
  - 3 channels for output (applicable to up to 4 types of data format)
- Surround DRAM access signal 16 accesses/CH Max. (within 1 fs)  
Up to 2 256K (64K x 4 bits) DRAMs or 1M (256K x 4 bits) DRAMs can be directly connected to this chip.
- Uses external DRAMs with RAS access times of 120 ns or lower
- Serial Input/Output interface with a microcomputer
  - Synchronous 8-bit serial input : 1  
[Mail box (16 bits x 8) function available]
  - Synchronous 8-bit serial output : 1

4) Interrupt function (Vectored interrupt with the INT pin)

5) Stack Nesting Levels : 4

6) On-chip Interval Timer : 12 bits (timer clock = sampling frequency)

7) Cycle time : 108ns (sampling frequency = 48kHz)

8) Single 5V power supply

9) Package : 64-pin DIPs (LC83010N)  
80-pin QFPs (LC83010NE)

Note) When soldering QFP devices, do not use the solder dip method.

10) Evaluation chip : LC83EV010N (PGA100)

- Applications
- Graphic Equalizer
- Power calculation for spectrum analyzer display
- Sound filed creation (using external DRAMs)
- 4 Speakers + REC output

# LC83010N, 83010NE

## Development Environment

- Software Tools
  - 1) Assembler
  - 2) Debugger with simulation
- Hardware Tools
  - 1) IBM PC-AT compatible machines or AX personal computers
  - 2) In Circuit Emulator (ICE)

## Package Dimensions 3071 (unit: mm)

[LC83010N]

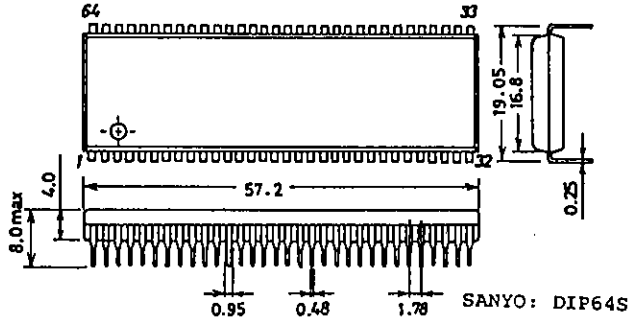

## Package Dimensions 3174 (unit: mm)

[LC83010NE]

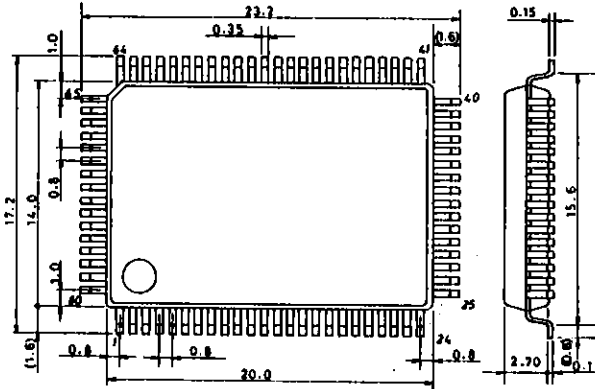

SANYO: QIP80E

## Pinout and Block Diagram

### Block Diagram

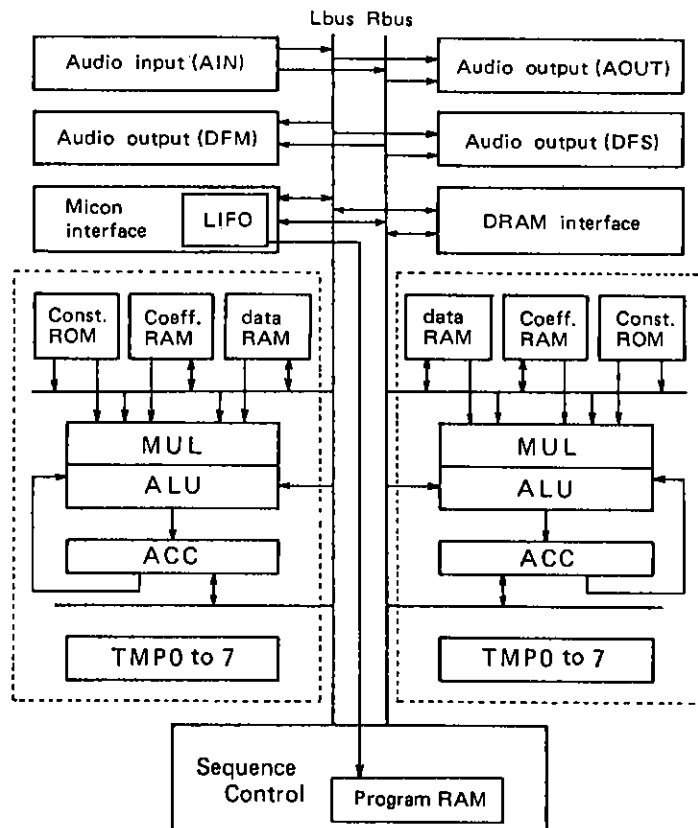

LC83010N, 83010NE

Pinout  
(DIP64S)

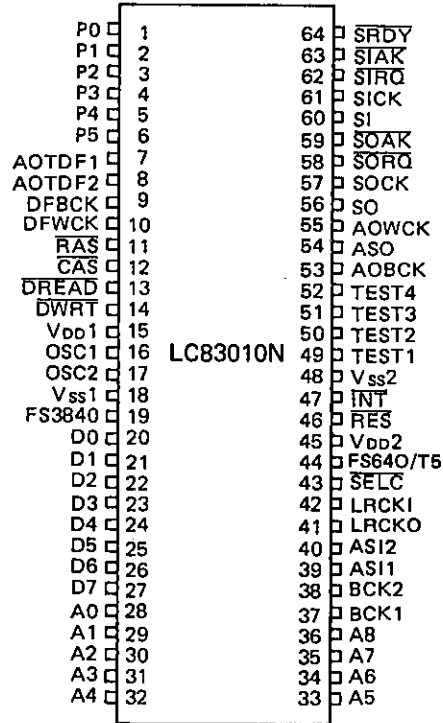

(QIP80E)

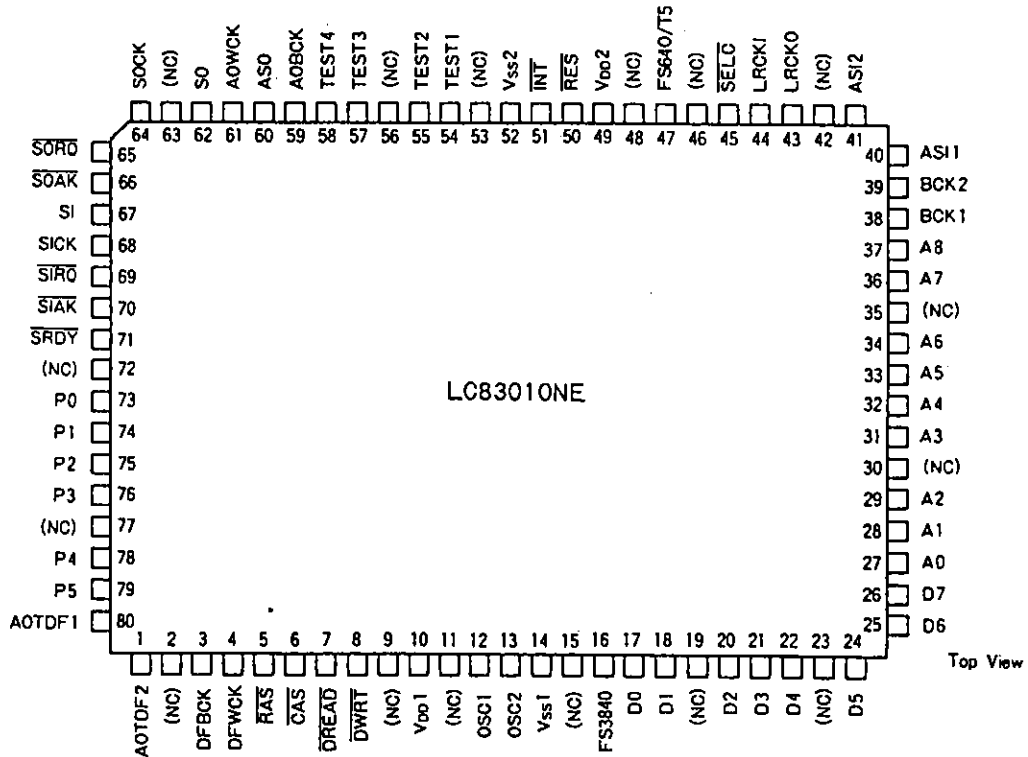

LC83010N, 83010NE

Pin Description

	Pin Name	I/O	Functional Description
	VDD1,2	I	+5V power supply pins (These pins should be connected to the positive power source.)
	VSS1,2	I	GND power supply pins (These pins should be connected to the ground level.)
Audio I/F (interface)	ASI1	I	Audio data serial Input 1
	ASI2	I	Audio data serial Input 2
	BCK1	I	Bit clock Input pin for ASI1 data
	BCK2	I/O	Bit clock Input pin for ASI2 data (I/O selectable by CR)
	LRCKI	I	Input pin for L/R channel distinguish signal (H: L channel data ; L: R channel data)
	LRCKO	O	Input pin for L/R channel distinguish signal (H: L channel data ; L: R channel data)
	ASO	O	Audio data serial output
	AOBCK	O	Bit clock output pin for ASO data (for 32fs and 48fs)
	AOWCK	O	Word clock output pin for ASO data
	AOTDF1	O	Serial output pin for audio data (for high presence 1)
	AOTDF2	O	Serial output pin for audio data (for high presence 2)
	DFBCK	O	Bit clock output pin for AOTDF1 and AOTDF2 data (for 32fs and 48fs)
	DFWCK	O	Word clock output pin for AOTDF1 and AOTDF2 data
DRAM I/F	$\overline{\text{RAS}}$	O	Output pin for RAS signal to external DRAMs
	$\overline{\text{CAS}}$	O	Output pin for CAS signal to external DRAMs
	$\overline{\text{DREAD}}$	O	Output pin for data read signal to external DRAMs
	$\overline{\text{DWRT}}$	O	Output pin for data write signal to external DRAMs
	A0 to 8	O	Output pins for address signals to external DRAMs (64K x 4 bits: A0 to A7, 256K x 4 bits: A0 to A8)
	D0 to 7	I/O	Input/output pins for data transfer with external DRAMs. In the single DRAM configuration mode, pins D0 to D3 are used. In the double DRAM configuration mode, pins D0 to D7 are used.
Microcomputer I/F	SI	I	Input pin for serial data from control microcomputer (8-bit serial data)
	$\overline{\text{SICK}}$	I	Serial clock input pin for SI data
	$\overline{\text{SIRQ}}$	I	Request signal input pin for serial data Input
	$\overline{\text{SIACK}}$	O	Output pin for Acknowledge response to the input request signal from a microcomputer
	$\overline{\text{SRDY}}$	I	Input pin for a Ready signal from a controlling microcomputer indicating the end of a data transfer
	SO	O	Output pin for serial data to a controlling microcomputer (8-bit serial data)
	$\overline{\text{SOCK}}$	I	Serial clock input pin for SO data
	$\overline{\text{SORQ}}$	I	Request signal input pin for serial data output
	$\overline{\text{SOACK}}$	O	Output pin for Acknowledge response to the output request signal from a microcomputer
	P0 to 5	I/O	General-purpose Input/Output ports (with on-chip pull-up resistor)
	OSC1	I	Pin for connection with a crystal oscillator or for clock input from an external source. (384fs)
	OSC2	O	Pin for connection with a crystal oscillator (should be left open in external clock input mode)
Control pins	FS3840	O	384fs output pin
	$\overline{\text{INT}}$	I	Interrupt request input pin (with on-chip pull-up resistor)
	$\overline{\text{RES}}$	I	Reset input pin (with on-chip pull-up resistor)
	$\overline{\text{SELC}}$	I	L/R channel signal select input pin with on-chip pull-down resistor ; L: external (LRCKI), H: internal (Internal divider output)
	TEST 1 to 4	I	Test signal input pins. Normally, these pins should be connected to the ground level.
	FS640/T5	O	Test signal output pins. 64fs clock output/test output. FS640/T5 functions as a test output in test mode and as a 64fs clock output for external A/D converters during normal operation.

Pin configuration types

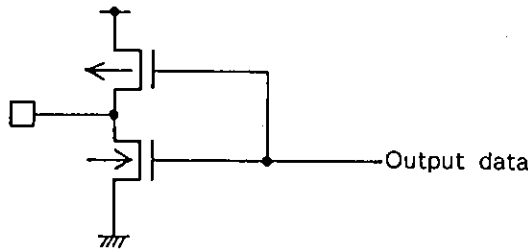
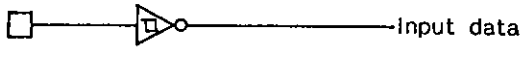
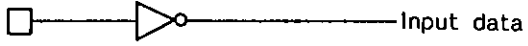
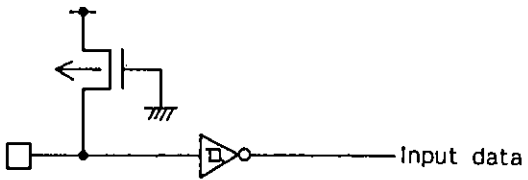
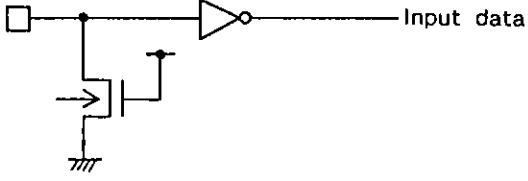
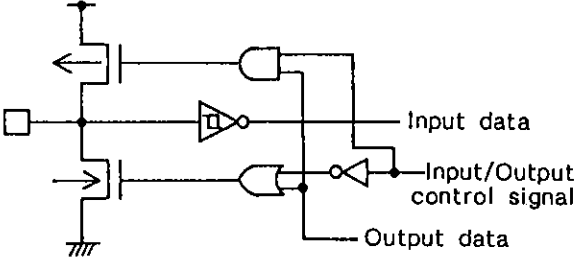
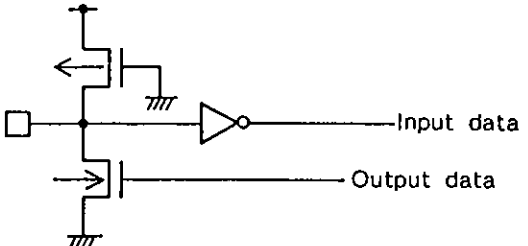
Level specification	Circuit type	Pin Name
TTL level output		ASO,AOBCK AOWCK, LRCKO,AOTDF1,AOTDF2, DFWCK, A0 to A8,FS3840, RAS,CAS,DREAD,DWRT, FS640/T5
CMOS medium level current output		SO, $\overline{SOAK}$ , $\overline{SI}$ AK
Schmitt input		$\overline{SOCK}$ , $\overline{SI}$ , $\overline{SICK}$ , $\overline{SORQ}$ , $\overline{SIRQ}$ , $\overline{SRDY}$
L level Schmitt input		BCK1,ASI1,ASI2,LRCKI
Normal input		TEST1 to 4
Input with internal pull-up resistor		$\overline{RES}$ , $\overline{INT}$
Input with internal pull-down resistor		$\overline{SELC}$
TTL level output Low level Schmitt input		BCK2,D0 to D7
Pu MOS medium current output Normal Input		P0 to P5

LC83010N, 83010NE

Electrical Specifications

Maximum Absolute Ratings/ $T_a=25^{\circ}\text{C}$ ,  $V_{SS}=0\text{V}$

Parameter	Symbol	Pins	Condition	Standard Values	unit	Note
Maximum Supply Voltage	$V_{DDmax}$			-0.3 to +7.0	V	
Output Voltage	V01	OSC2 output		Up to the voltage produced by oscillation	V	
	V02	Pins except for the OSC2		-0.3 to $V_{DD}+0.3$	V	
Input Voltage	$V_{IN}$			-0.3 to $V_{DD}+0.3$	V	
Peak Output Current	$I_{OP1}$	Audio I/F DRAM I/F		-2 to +4	mA	1
	$I_{OP2}$	Microcomputer I/F		-2 to +10	mA	2
	$I_{OP3}$	P0 to 5		-0.5 to +10	mA	3
Average Output Current	$I_{OA1}$	Audio I/F	Per pin	-2 to +4	mA	4
	$I_{OA2}$	Audio I/F DRAM I/F	Per pin	-2 to +4	mA	5
	$I_{OA3}$	Microcomputer I/F	Per pin	-2 to +10	mA	2
	$I_{OA4}$	P0 to 5	Per pin	-0.5 to +10	mA	3
	$\Sigma I_{OA1}$	Audio I/F	Total	-11 to +45	mA	4
	$\Sigma I_{OA2}$	Audio I/F DRAM I/F	Total	-4 to +15	mA	5
	$\Sigma I_{OA3}$	Microcomputer I/F	Total	4 to +15	mA	2
	$\Sigma I_{OA4}$	P0 to 5	Total	-3 to +30	mA	3
Allowable Power Dissipation	$P_{d\ max}$		$T_a=-30$ to $+70^{\circ}\text{C}$	600	mW	
Operating Ambient Temperature Range	$T_{opg}$			-30 to +70	$^{\circ}\text{C}$	
Storage temperature range	$T_{stg}$			-40 to +125	$^{\circ}\text{C}$	

※ When soldering QFP devices, do not use the solder dip method.

LC83010N, 83010NE

Allowable Operating Conditions (Ta=-30°C to +70°C, VDD=4.75V to 5.25V, VSS=0V, unless otherwise noted)

Parameter	Symbol	Pins and Conditions	Standard values			unit	Note
			min	typ	max		
Operating Supply Voltage	VDD		4.75		5.25	V	
High Level Input Voltage	VIH1	Audio I/F, DRAM I/F	2.4			V	6
	VIH2	P0 to P5, $\overline{SELC}$ , TEST1 to 4	0.7VDD			V	
	VIH3	$\overline{RES}$ , $\overline{INT}$ , Microcomputer I/F	0.75VDD			V	7
Low Level Input Voltage	VIL1	Audio I/F, DRAM I/F			0.8	V	6
	VIL2	P0 to P5, $\overline{SELC}$ , TEST1 to 4			0.3VDD	V	
	VIL3	$\overline{RES}$ , $\overline{INT}$ , Microcomputer I/F			0.25VDD	V	7
Operating Frequency (Instruction Cycle Time)	fOP (TCYC)	Up to 1% crystal oscillation error is allowed. max:48kHzX384X1.01	12.17 (165)		18.62 (107)ns	MHz (ns)	
External Clock Input Conditions	Frequency	fEXT	Applies to the OSC1 pin. See Figure 1. (OSC1 : input, OSC2: Open)	12.17	18.62	MHz	
	Pulse width	tEXTH tEXTL		20		ns	
	Rise Time Fall Time	tEXTR tEXTF			10	ns	
Self-oscillation Conditions Crystal Oscillation	Oscillation Frequency	fEXT	OSC1, OSC2 See Figure 2.		18.62	MHz	
	Oscillation Stabilizing Period	fEXTS	See Figure 3.			ms	
Audio Data Input Conditions	Transfer Bit Clock Cycle	tBCYC	Applies to the BCK1 and BCK2 pins. See Figure 4.	325		ns	
	Transfer Bit Clock Pulse Width	tBCW		100		ns	
	Date Set up Time	tS		75		ns	
	Data Hold Time	tH		75		ns	

Continued on the next page.

Continued from the preceding page.

Parameter	Symbol	Pins and Conditions	Standard Values			unit	Note	
			min	typ	max			
Serial I/O Clock Conditions	Serial Clock Cycle	tSCYC	Applies to the microcomputer interface. See Figure 5. (Applies to the SICK, SOCK and SI pins.)	650			ns	
	Serial Clock Pulse Width	tSCW		325			ns	
	Data set up Time	tSS		75			ns	
	Data Hold Time	tSH		75			ns	
DRAM Input Conditions	Date Set up Time	tDS	Applies to the data input from external DRAM. See Figure 6. (Timings between $\overline{RAS}$ , $\overline{CAS}$ and D0 to D7)	41			ns	8
	Data Hold Time	tDH		0			ns	8



LC83010N, 83010NE

Electrical Characteristics (Ta=-30°C to +70 °C. VDD=4.75V to 5.25V. VSS=0V, unless otherwise noted)

Parameter	Symbol	Pins and Conditions	Standard Values			unit	Note	
			min	typ	max			
Low Level Input Current	I <sub>IL1</sub>	$\overline{\text{RES}}, \overline{\text{INT}}$ V <sub>IN</sub> =V <sub>SS</sub>	-250			μA		
	I <sub>IL2</sub>	P0 to P5 V <sub>IN</sub> =V <sub>SS</sub>	-1			mA		
High Level Input Current	I <sub>IH</sub>	$\overline{\text{SEL}}\overline{\text{C}}$ , Input pin with pull-down resistor			250	μA		
High Level Output Voltage	V <sub>OH1</sub>	I <sub>OH</sub> =-0.4mA	4.0			V	1	
	V <sub>OH2</sub>	I <sub>OH</sub> =-50μA	V <sub>DD</sub> -1.2			V	2,3	
Low Level Output Voltage	V <sub>OL1</sub>	I <sub>OL</sub> =2mA			0.4	V	1	
	V <sub>OL2</sub>	I <sub>OL</sub> =10mA			1.5	V	2,3	
Input Leakage Current		V <sub>IN</sub> =V <sub>SS</sub> to V <sub>DD</sub>	-10		10	μA		
Output-off Leakage Current	I <sub>OFF</sub>	V <sub>O</sub> =V <sub>SS</sub> , V <sub>DD</sub>	-40		40	μA		
Input/Output Capacitance					10	pF		
Audio Data Output Timing	Output Data Hold Time	t <sub>OH</sub>	Applies to audio data output. See Figure 7.			20	ns	
	Output Data Delay	t <sub>OD</sub>			100	ns		
Microcomputer I/F Output Delay	Output Data Delay	t <sub>SD</sub>	Applies to serial data output. See Figure 8.			100	ns	

Continued on the next page.

■ No products described or contained herein are intended for use in surgical implants, life-support systems, aerospace equipment, nuclear power control systems, vehicles, disaster/crime-prevention equipment and the like, the failure of which may directly or indirectly cause injury, death or property loss.

■ Anyone purchasing any products described or contained herein for an above-mentioned use shall:

- ① Accept full responsibility and indemnify and defend SANYO ELECTRIC CO., LTD., its affiliates, subsidiaries and distributors and all their officers and employees, jointly and severally, against any and all claims and litigation and all damages, cost and expenses associated with such use;
- ② Not impose any responsibility for any fault or negligence which may be cited in any such claim or litigation on SANYO ELECTRIC CO., LTD., its affiliates, subsidiaries and distributors or any of their officers and employees jointly or severally.

■ Information (including circuit diagrams and circuit parameters) herein is for example only; it is not guaranteed for volume production. SANYO believes information herein is accurate and reliable, but no guarantees are made or implied regarding its use or any infringements of intellectual property rights or other rights of third parties.

Continued from the preceding page.

Parameter	Symbol	Pins and Conditions	Standard Values			unit	Note	
			min	typ	max			
Access Timings for External DRAM	$\overline{\text{RAS}}$ "H" Pulse Width	t <sub>RP</sub>	Data output timing for external DRAM. See Figure 9.	95			ns	8
	$\overline{\text{RAS}}$ "L" Pulse Width	t <sub>RAS</sub>	(Note) DRAM which has RAS access time below 120ns should be used.	150			ns	8
	$\overline{\text{CAS}}$ "H" Pulse Width	t <sub>CP</sub>		80			ns	8
	$\overline{\text{CAS}}$ "L" Pulse Width	t <sub>CAS</sub>		101			ns	8
	$\overline{\text{RAS}}$ Address Set up Time	t <sub>RS</sub>		0			ns	8
	$\overline{\text{RAS}}$ Address Hold Time	t <sub>RH</sub>		20			ns	8
	$\overline{\text{CAS}}$ Address Set up Time	t <sub>CS</sub>		0			ns	8
	$\overline{\text{CAS}}$ Address Hold Time	t <sub>CH</sub>		40			ns	8
	$\overline{\text{DWRT}}$ Pulse Width	t <sub>W</sub>		50			ns	8
	$\overline{\text{CAS}}$ -before-WRITE Set up Time	t <sub>WC</sub>		0			ns	8
	Data Set up Time	t <sub>SD</sub>		0			ns	8
	Data Hold Time	t <sub>HD</sub>		50			ns	8
Crystal Oscillation	C1,C2	OSC1,OSC2 See Figure 2.		20			pF	
Current Dissipation	I <sub>DD</sub>	V <sub>DD1,2</sub> 18.62MHz external clock		50	100		mA	

(Note 1) TTL level output pins: ASO, AOBCK, AOWCK, LRCKO, BCK2, AOTDF1, AOTDF2, DFBCK, DFWCK, D0 to D7, A0 to A8, FS3840,  $\overline{\text{RAS}}$ ,  $\overline{\text{CAS}}$ ,  $\overline{\text{DREAD}}$ ,  $\overline{\text{DWRT}}$  and FS640/T5

(Note 2) CMOS medium current outputs: SO,  $\overline{\text{SOAK}}$ , and  $\overline{\text{SIK}}$

(Note 3) Pu MOS medium current outputs: P0 to P5

(Note 4) TTL level outputs (first group): ASO, AOBCK, AOWCK, LRCKO, A0 to A8, D0 to D7, FS3840 and BCK2

(Note 5) TTL level outputs (second group): AOTDF1, AOTDF2, DFWCK,  $\overline{\text{RAS}}$ ,  $\overline{\text{CAS}}$ ,  $\overline{\text{DREAD}}$ ,  $\overline{\text{DWRT}}$ , and DFBCK

(Note 6) L level Schmitt inputs pin: BCK1, BCK2, ASI1, ASI2, LRCKI, and D0 to D7

(Note 7) Schmitt input pins:  $\overline{\text{RES}}$ ,  $\overline{\text{INT}}$ ,  $\overline{\text{SOCK}}$ , SI, SICK,  $\overline{\text{SORQ}}$ ,  $\overline{\text{SIRQ}}$ , and  $\overline{\text{SRDY}}$

(Note 8) The maximum load capacitance of  $\overline{\text{RAS}}$ ,  $\overline{\text{CAS}}$ ,  $\overline{\text{DREAD}}$ ,  $\overline{\text{DWRT}}$ , D0 to D7 and A0 to A8 is 50pF.

Figure 1. External input clock waveform (OSC1)

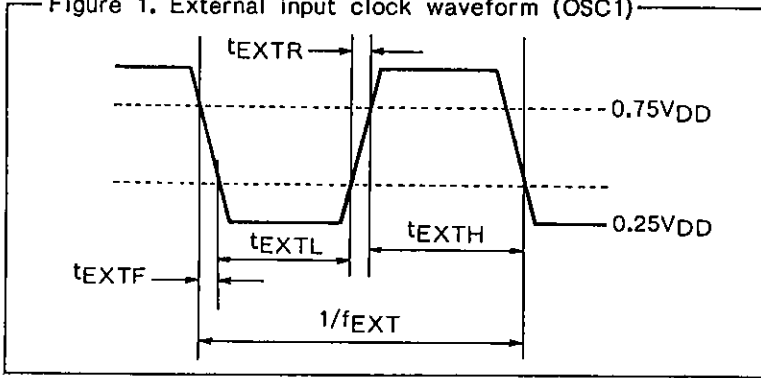

Figure 2. Crystal oscillation circuit

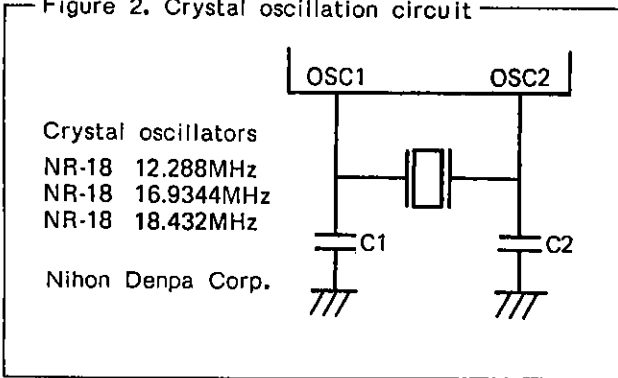

Figure 3. Oscillation stabilizing period

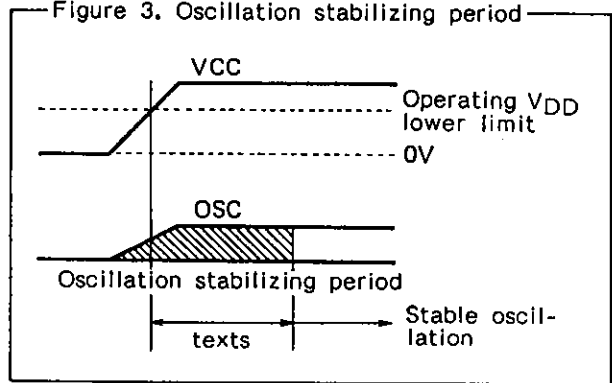

Figure 4. Audio data input conditions

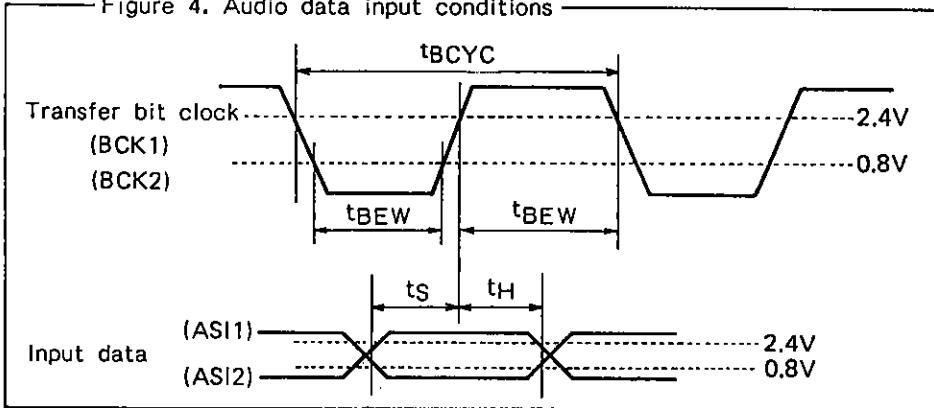

Figure 5. Microcomputer Interface

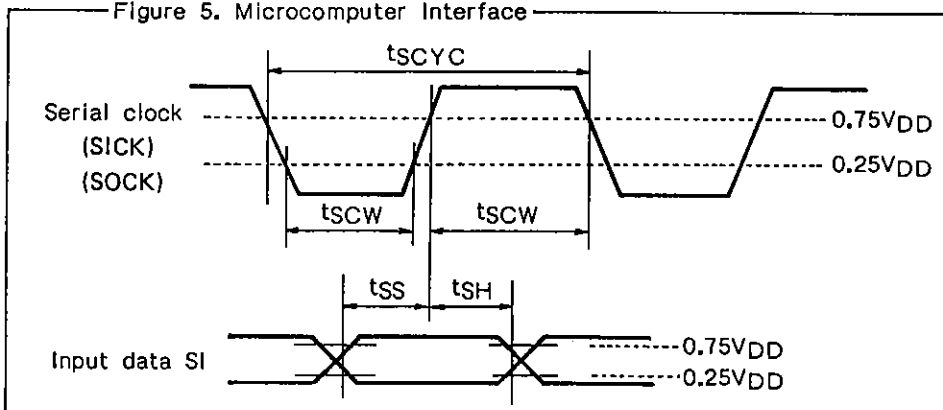

Figure 6. External DRAM data input condition ( $\overline{DREAD} = L$ )

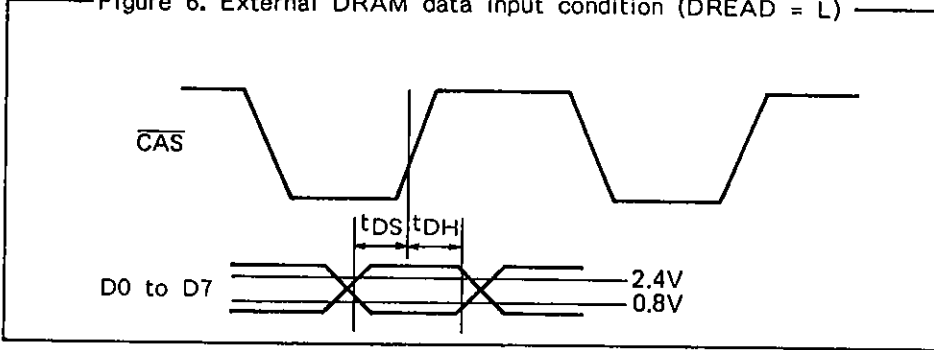

Figure 7. Audio data output timing

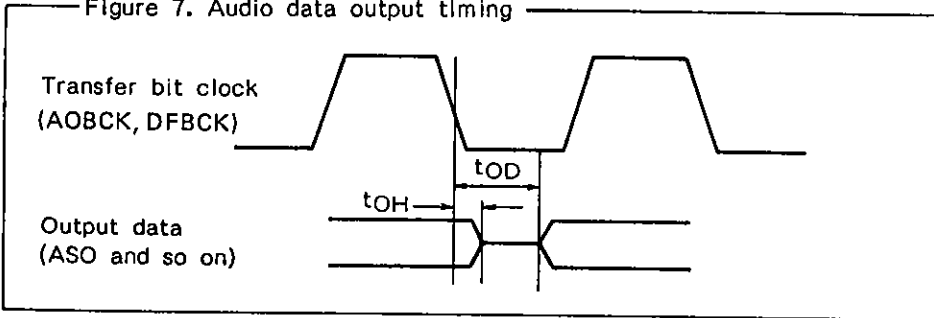

Figure 8. Microcomputer interface serial output timing

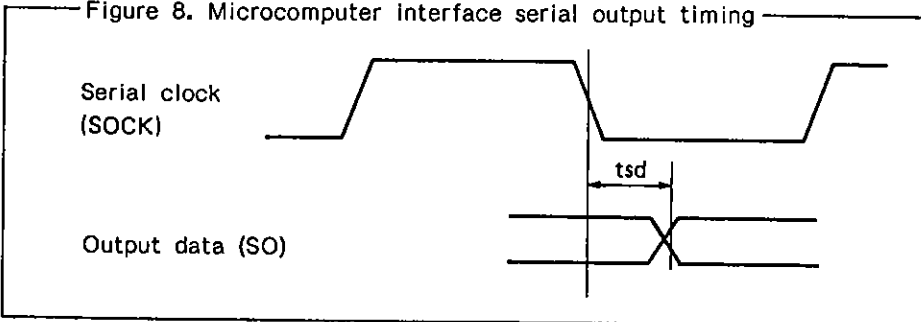
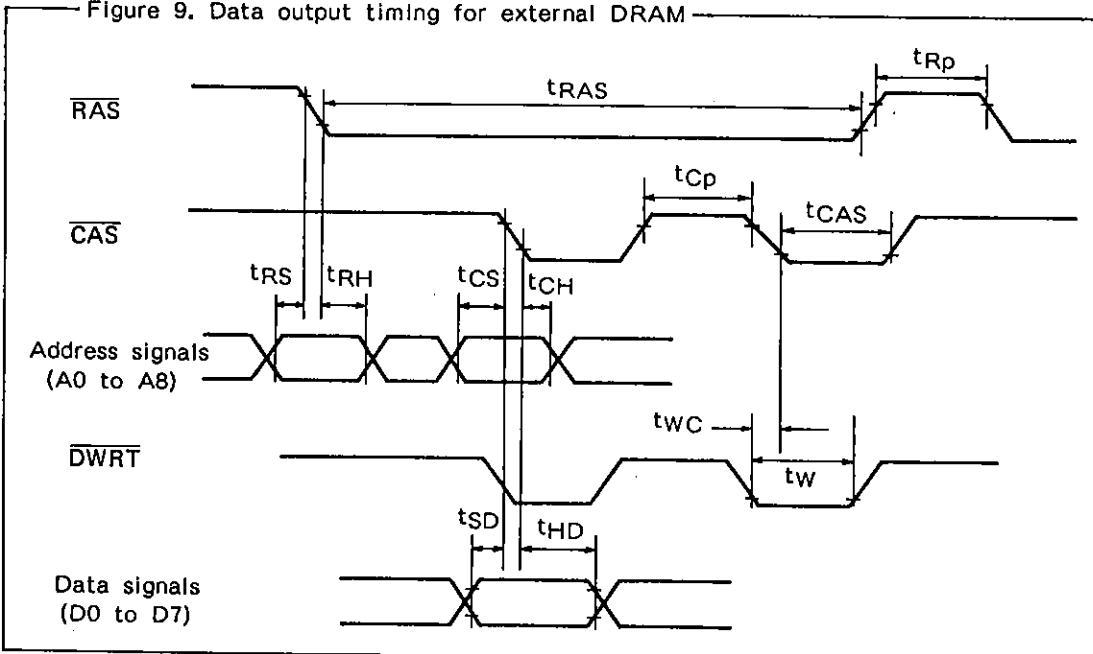

Figure 9. Data output timing for external DRAM



Program load to the LC83010N

- Boot procedure -

Programs must be loaded (boot strap) into the LC83010N (D<sup>2</sup>SP) from an external control unit (microcomputer) because its internal program memory consists of RAMs. The capacity of the program memory is 320 words x 32 bits.

The procedural flow to load a 320-word program into the D<sup>2</sup>SP from a controlling microcomputer is shown in Figure A-1.

- (1) Reset the entire system (microcomputer and D<sup>2</sup>SP) or reset the D<sup>2</sup>SP from the controlling microcomputer. After the D<sup>2</sup>SP is reset, it then enters the Boot mode.
  - (2) Transfer the program to the D<sup>2</sup>SP from the microcomputer. The program is transferred to the D<sup>2</sup>SP in 8-bit synchronous serial communication mode. The program data of 8 bits x 16 data (equal to 4 instructions) is transferred to the D<sup>2</sup>SP continuously from the microcomputer, and followed by the SRDY signal. The D<sup>2</sup>SP stores that program data of 4 instructions to the internal mail box. The program data is then moved to the program RAM at the moment when the SRDY signal reaches the D<sup>2</sup>SP.
  - (3) The operations discussed in (2) are repeated 80 times until the program data transfer of 320 instructions from the microcomputer to the D<sup>2</sup>SP is complete.
  - (4) The D<sup>2</sup>SP automatically starts the program execution when the program loading of 320 instructions is complete.
- The program is transferred to the D<sup>2</sup>SP from the microcomputer in that manner.

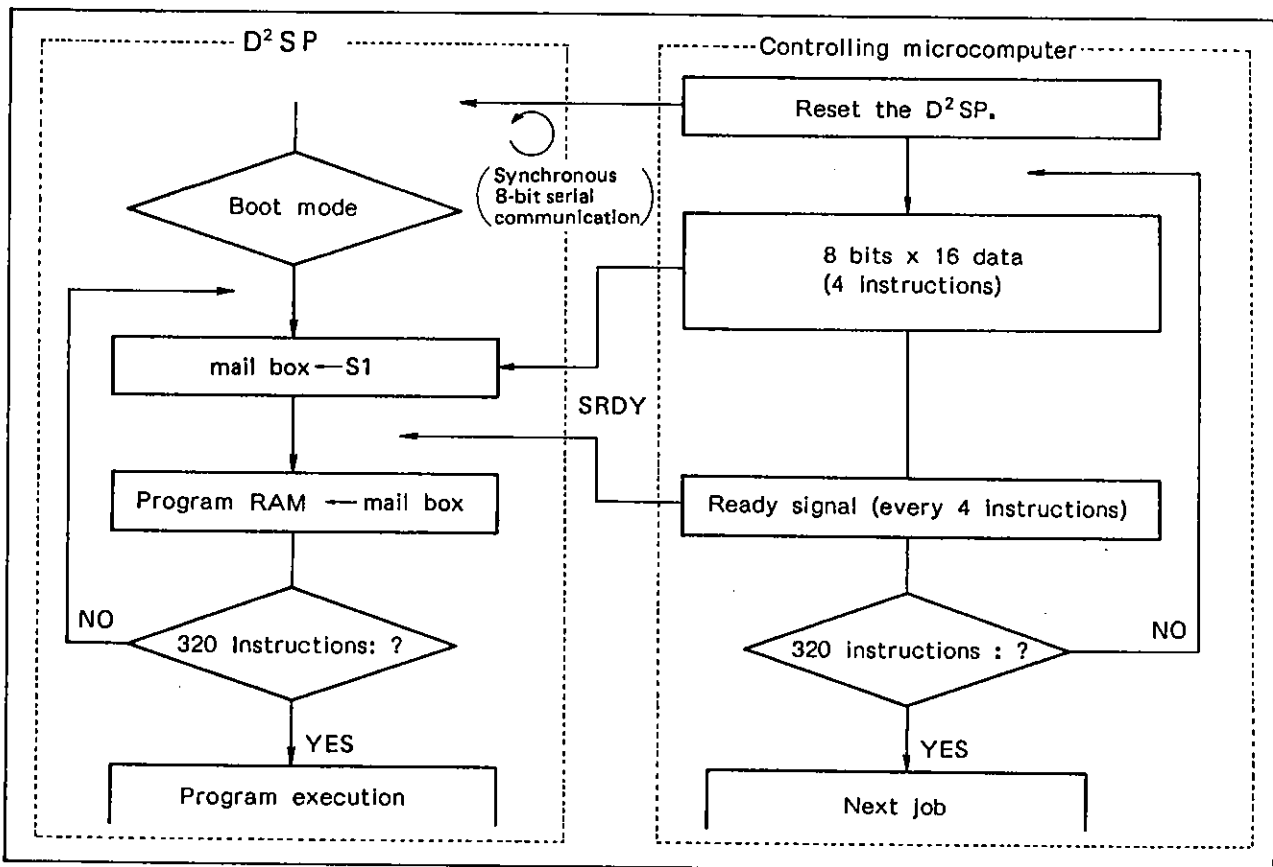

Figure A-1. Example Program Boot flow (D<sup>2</sup>SP ← Microcomputer)

Figure A-2 gives the outline of an example program Boot system.

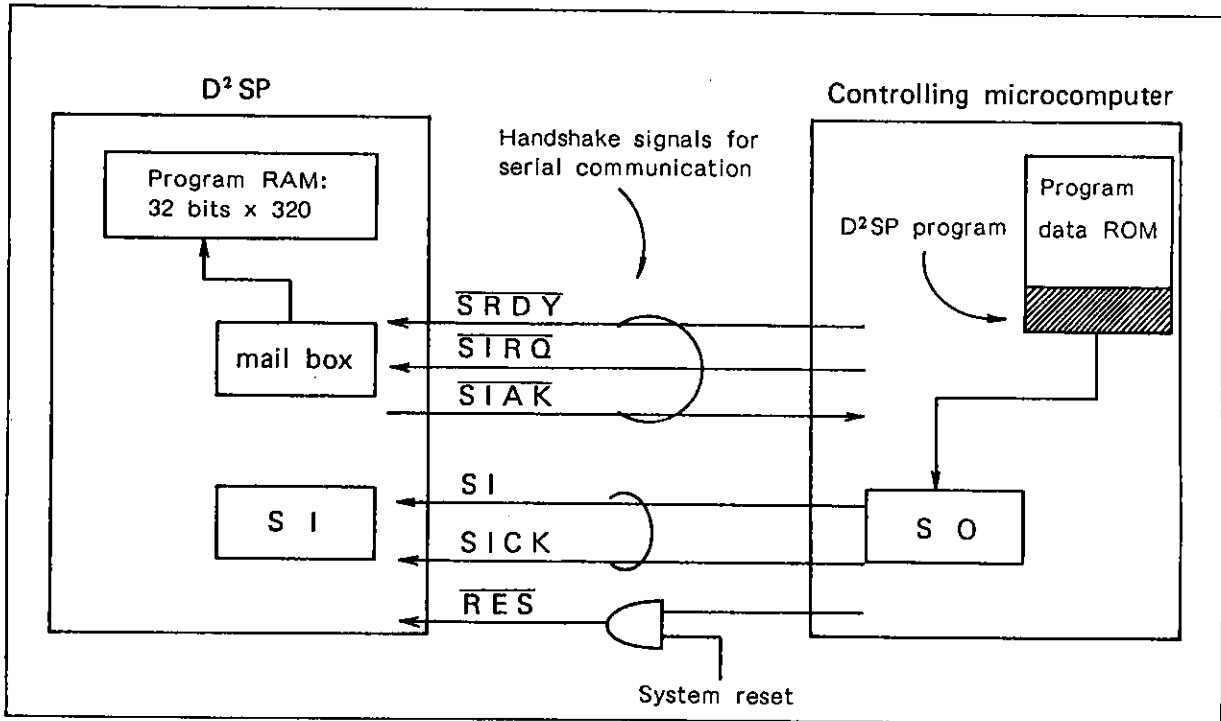

Figure A-2. Outline of an example program Boot system

**Development tool system**

- Program development flow -

Development tools are provided to help the user to easily develop application programs for the D²SP. These development tools are divided into two groups: software support tool group and hardware support tool group. The software support tool group consists of an assembler, debugger and simulator.

The hardware support tool group is realized as an In-Circuit Emulator (ICE).

Figure A-3 shows the applications development flow for the D²SP system.

- (1) Write an application source program.
- (2) Check the source program for syntax errors with the assembler. If every syntax error is corrected, the assembler generates a HEX program file.
- (3) Check the HEX file for operational errors with the simulator. If the desired operations are not successful, start the debugger to find what caused logical errors.
- (4) If program operations are checked successfully, use the ICE to evaluate the audio signal output. First, evaluate sound signals only with the ICE. In this evaluation process, the delay memory and microcomputer of the ICE are used. Second, start the total evaluation on an application system. In this evaluation stage, the AD/DA converters, microcomputer, and delay memory on the user application system are used.

Figure A-4 shows the entire program development tool system for the D²SP.

The software tools such as the assembler, debugger, simulator can be run on an IBM PC-AT compatible machine or an AX personal computer. The ICE is also controlled by such a host personal computer.

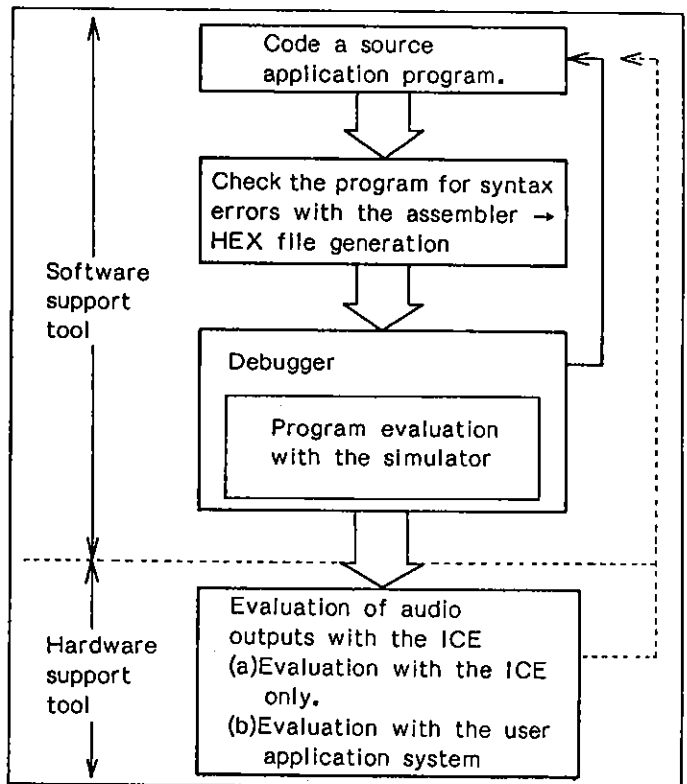

Figure A-3. Applications Development Flow

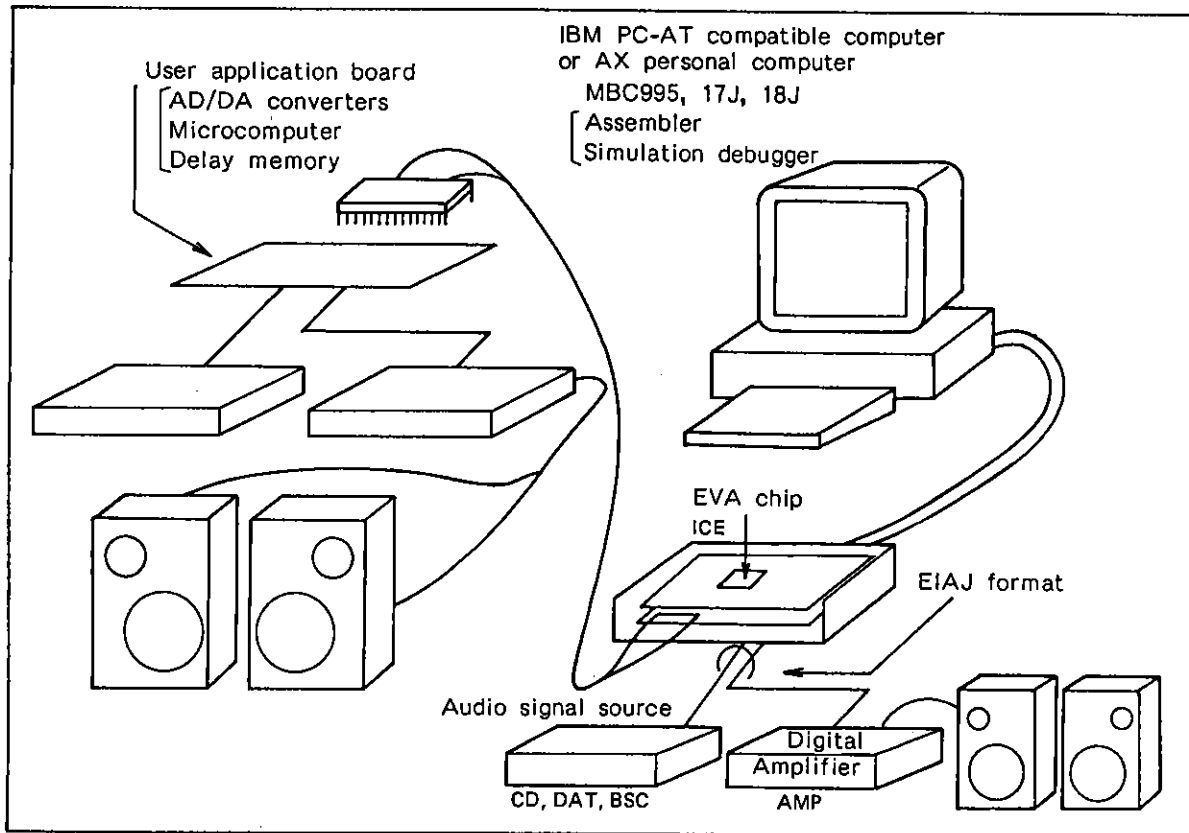

Figure A-4. Entire support tool system for microprogram development

#### (1) Debugger

The debugger is a software support tool designed to realize virtual D<sup>2</sup>SP functional circuits. In this virtually emulated D<sup>2</sup>SP environment, user application programs can be evaluated as if they were executed on the real chip. The debugger is used mainly for logics analysis and detailed data analysis. Major functions of the debugger are listed in the table below, with brief explanation for each.

- Display and Edit instructions  
These instructions can be used to display the contents of memory and registers on a screen and to update them.
- Memory Fill instruction  
This instruction is used to fill a specified memory address range with a desired value.
- Move instruction  
This instruction is used to transfer the data in a specified memory address range to another range.
- Memory Load and Save instructions  
These instructions are used to transfer data between memory and disk. The memory load instruction enables the data transfer from a disk file to memory while the memory save instruction allows the data transfer from memory to a disk file.
- Assemble and Unassemble instructions  
The assemble instruction is used to convert mnemonics into machine codes.  
The unassemble instruction is used to convert memory data back to mnemonics.
- Emulation instruction control instruction and Break point instruction  
These instructions are used to execute the D<sup>2</sup>SP program and trace its operations. The break point instruction is used to set a point where the program execution stops.

Table Major debugger functions

## (2) Outline of the simulator functions

The application programs can be tested in the following sequence:

- Inputting digital audio signals to the D<sup>2</sup>SP chip,
- Executing a program,
- Converting the audio output into analog signals, and
- Measuring the analog signals with an oscilloscope or frequency characteristics meter (or sweep meter).

The simulator enables the above operations on a personal computer.

Figure A-5 shows the signal waveform measurement.

This simulator has the following three measurement functions:

- 1) Audio output waveforms (sine waves) with respect to audio input waveforms (sine waves)
- 2) Frequency characteristics of audio output (AOUT)
- 3) Impulse response characteristics of audio output

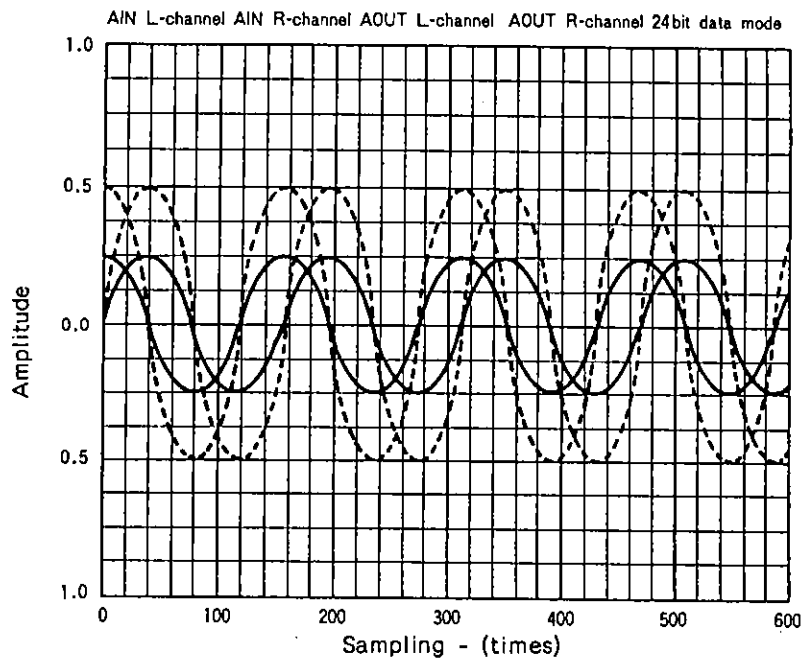

Figure A-5. Display of various waveforms



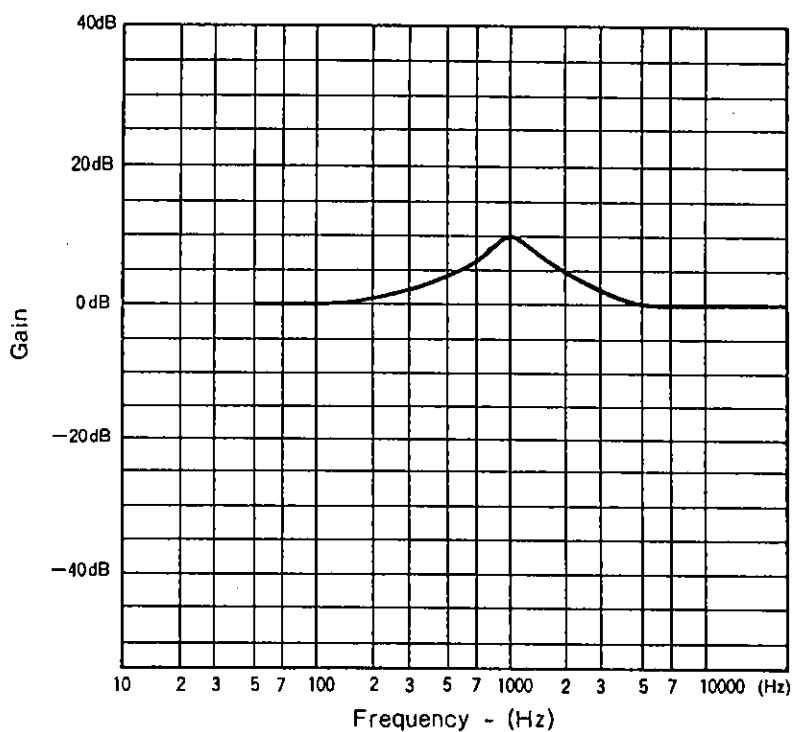

Figure A-6. Display of frequency characteristics

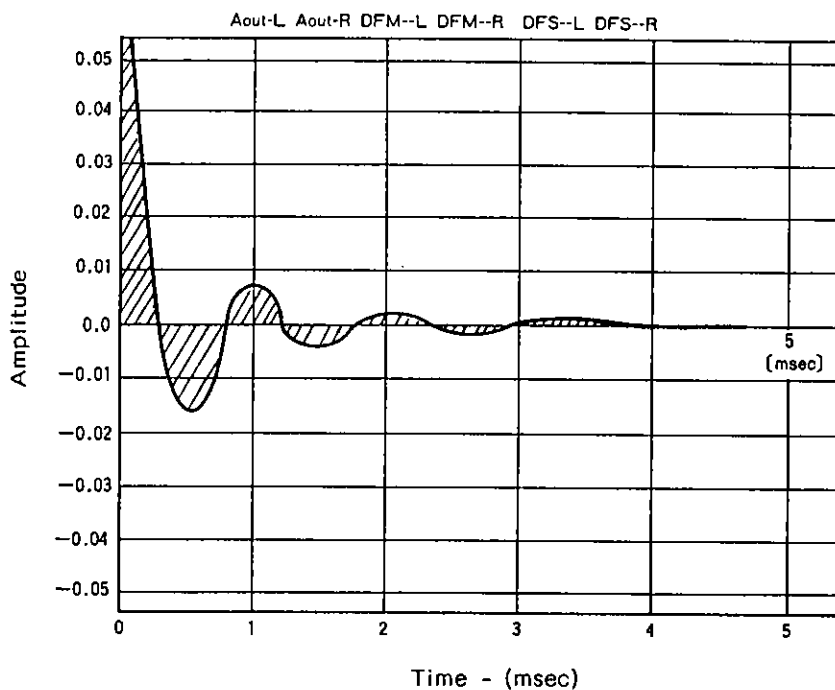

Figure A-7. Impulse response waveforms (limit cycle characteristic)

## (3) ICE outline

The In-Circuit Emulator (ICE) provides an operating environment where the application program already checked by the simulation debugger is executed and then outputs audio signals. The ICE functions can be divided into two: One is the program evaluation by outputting audio signals only on the ICE. In this evaluation method, delay can be produced by the DRAM in the ICE system. The other is the final program evaluation by connecting a user application board to the ICE system. In this test method, the interfaces to the controlling microcomputer and other various peripheral LSIs on the application board can be evaluated. Figure A-8 shows the ICE system configuration for the entire evaluation using a user application board.

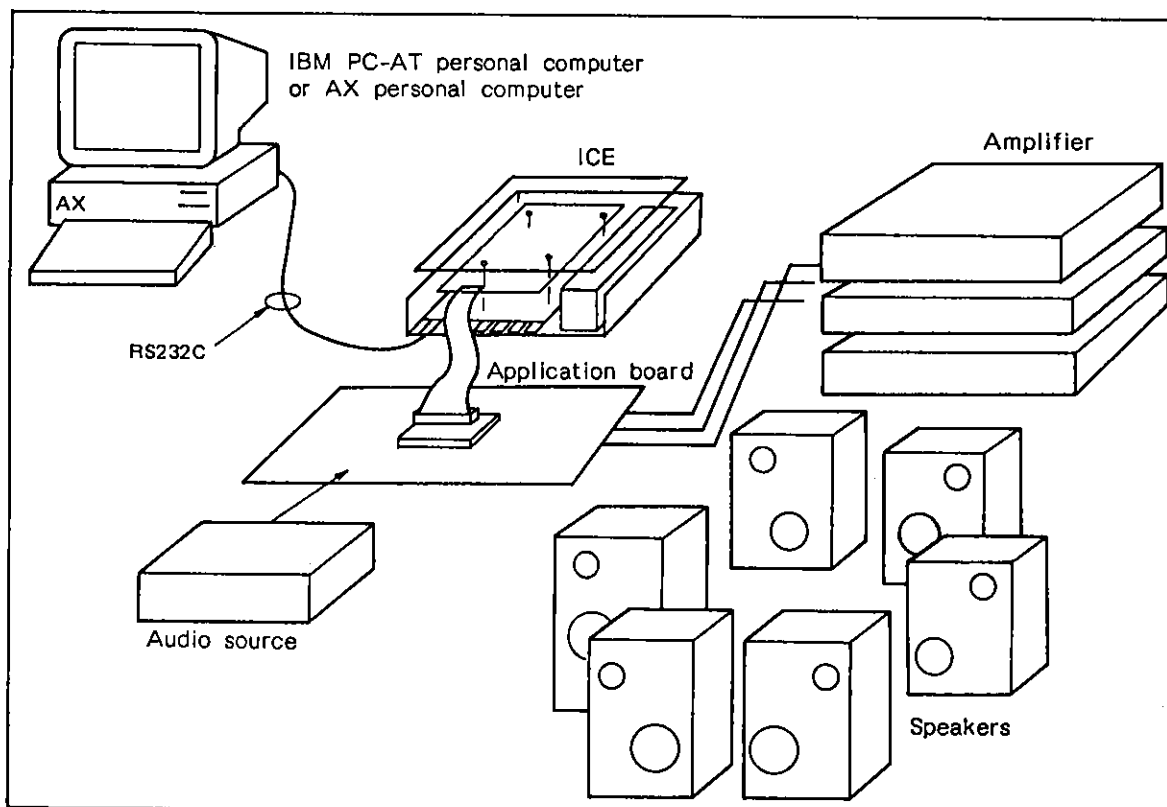

Figure A-8. Final evaluation system configuration with an application board and ICE

## ICE functions

- The ICE has debugging functions.
- The ICE consists of unique hardware functions specifically designed as the ICE for audio DSP.

## (a) ICE debugging functions

- (1) Execution command : Allows the program execution to continue until a break point is detected. It also enables the program execution in the step mode or in the trace mode.
- (2) Break function : Enables the user to set a desired break point.
- (3) The edit dump command is useful in displaying the conditions of a specified memory area after the break of program execution. The register edit command is used to convert the contents of a present specified register.
- (4) The memory dump command is useful in displaying the contents of a specified memory area when the program execution breaks. On the other hand, the edit command is used to edit the contents of a specified memory area when the program execution breaks.
- (5) Program modification and confirmation : Enables the user to modify part of the program and to check how it works.
- (6) Other functions : Memory management facility and so on. For details, refer the sections following section 8-3.

## (b) Unique ICE hardware configuration

- (1) Audio data input/output : Digital Interface Receiver (DIR).  
This function allows direct input of audio digital data. Digital Interface Transmitter (DIT). This function allows direct output of 3-channel digital audio data.
- (2) DRAM : Delay DRAM for audio signal. 256k (64K x 4 bits) x 2. 1M (256K x 4 bits) x 2
- (3) Evaluation function of serial input/output : Z80 microcomputer for evaluating serial input/output. This control unit makes an access to the D<sup>2</sup>SP instead of any controlling microcomputer to adjust the serial input/output operations.



LC83010N, 83010NE

Instruction Bit Map

The instruction bit map is shown below.

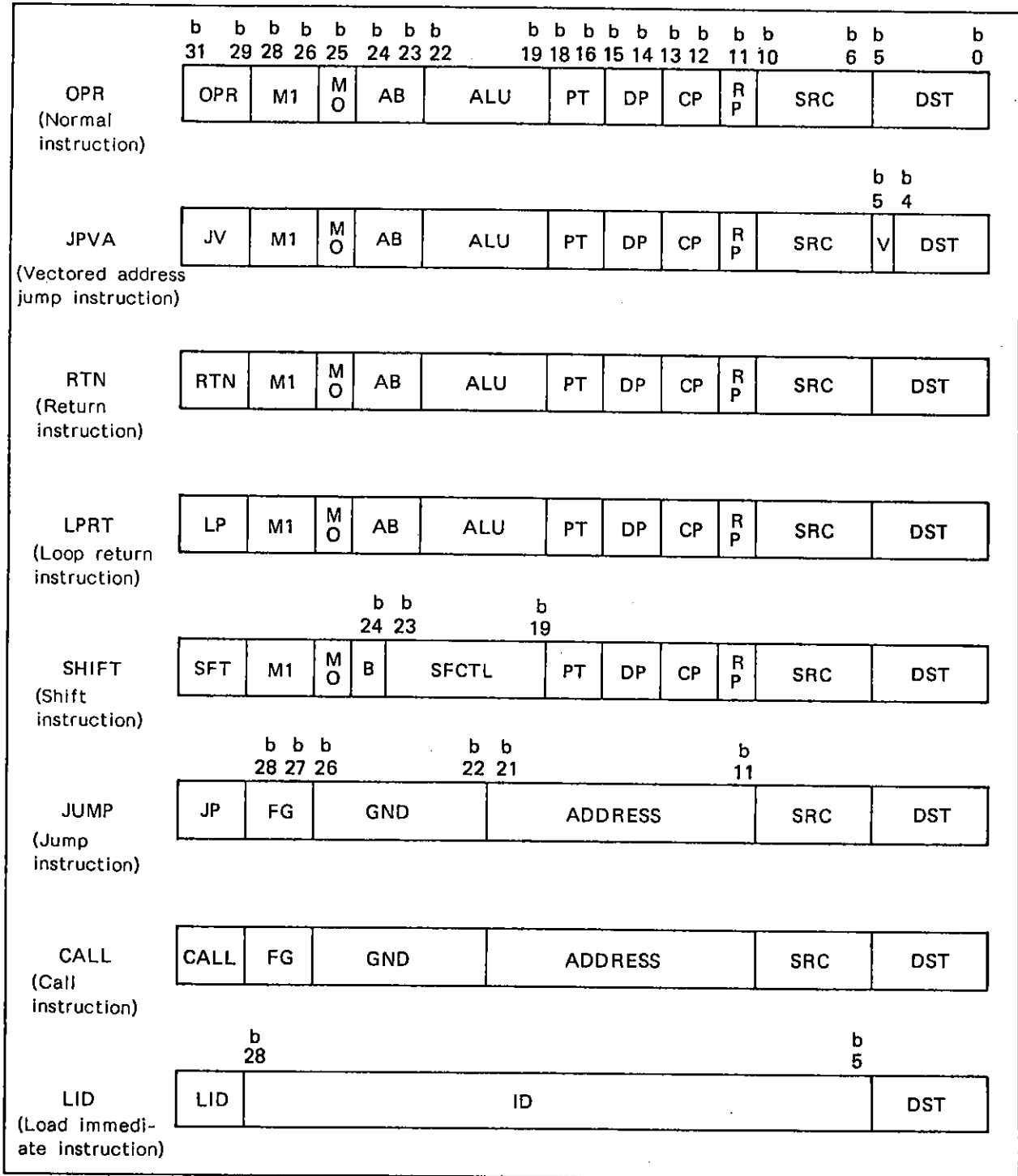

Instruction Bit Map diagram