



SANYO Semiconductors

DATA SHEET

An ON Semiconductor Company

LB11967V

Monolithic Digital IC

For Variable Speed Fan Motor

Single-Phase Full-Wave Pre-Driver

Overview

The LB11967V is a single-phase bipolar variable speed fan motor pre-driver that works with an external PWM signal.

A highly efficient, quiet and low power consumption motor driver circuit, with a large variable speed, can be implemented by adding a small number of external components.

This device is optimal for driving large scale fan motors (with large air volume and large current) such as those used in servers and consumer products.

Functions

- Pre-driver for single-phase full-wave drive
 - ⇒ PNP-EMOS is used as an external power Transistor, enabling high-efficiency low-consumption drive by means of the low-saturation output and single-phase full-wave drive. (PMOS-NMOS also applicable)
- External PWM input enabling variable speed control
 - ⇒ Separately-excited upper direct PWM ($f = 25\text{kHz}$) control method, enabling highly silent speed control
- Compatible with 12V, 24V, and 48V power supplies
- Current limiter circuit incorporated
 - ⇒ Chopper type current limit at start
- Reactive current cut circuit incorporated
 - ⇒ Reactive current before phase change is cut to enable silent and low-consumption drive.
- Minimum speed setting pin
 - ⇒ Minimum speed can be set with external resistor. The start assistance circuit enables start at extremely low speed.
- Constant-voltage output pin for Hall bias
- Lock protection and automatic reset functions incorporated
- (Rotation speed detection), RD (Lock detection) output

■ Any and all SANYO Semiconductor Co.,Ltd. products described or contained herein are, with regard to "standard application", intended for the use as general electronics equipment (home appliances, AV equipment, communication device, office equipment, industrial equipment etc.). The products mentioned herein shall not be intended for use for any "special application" (medical equipment whose purpose is to sustain life, aerospace instrument, nuclear control device, burning appliances, transportation machine, traffic signal system, safety equipment etc.) that shall require extremely high level of reliability and can directly threaten human lives in case of failure or malfunction of the product or may cause harm to human bodies, nor shall they grant any guarantee thereof. If you should intend to use our products for applications outside the standard applications of our customer who is considering such use and/or outside the scope of our intended standard applications, please consult with us prior to the intended use. If there is no consultation or inquiry before the intended use, our customer shall be solely responsible for the use.

■ Specifications of any and all SANYO Semiconductor Co.,Ltd. products described or contained herein stipulate the performance, characteristics, and functions of the described products in the independent state, and are not guarantees of the performance, characteristics, and functions of the described products as mounted in the customer's products or equipment. To verify symptoms and states that cannot be evaluated in an independent device, the customer should always evaluate and test devices mounted in the customer's products or equipment.

SANYO Semiconductor Co., Ltd.

<http://semicon.sanyo.com/en/network>

LB11967V

Specifications

Maximum Ratings at $T_a = 25^\circ\text{C}$

Parameter	Symbol	Conditions	Ratings	Unit
V_{CC} maximum supply voltage	$V_{CC\text{ max}}$		18	V
OUT pin maximum output current	$I_{OUT\text{ max}}$		50	mA
OUT pin output withstand voltage	$V_{OUT\text{ max}}$		18	V
HB maximum output current	$I_{HB\text{ max}}$		10	mA
VTH input pin withstand voltage	$V_{VTH\text{ max}}$		8	V
RD/FG output pin output withstand voltage	$V_{RD}/V_{FG\text{ max}}$		18	V
RD/FG output current	$I_{RD}/I_{FG\text{ max}}$		10	mA
Allowable power dissipation	$P_d\text{ max}$	Mounted on a specified board*	800	mW
Operating temperature range	T_{opr}		-30 to +95	$^\circ\text{C}$
Storage temperature range	T_{stg}		-55 to +150	$^\circ\text{C}$

*Specified board: 114.3mm × 76.1mm × 1.6mm, glass epoxy board.

Recommended Operating Conditions at $T_a = 25^\circ\text{C}$

Parameter	Symbol	Conditions	Ratings	Unit
V_{CC} supply voltage	V_{CC}		6 to 16	V
VTH input level voltage range	VTH	Full speed mode	0 to 7	V
Hall input common phase input voltage range	VICM		0.2 to 3	V

Electrical Characteristics at $T_a = 25^\circ\text{C}$, $V_{CC} = 12\text{V}$, unless otherwise specified.

Parameter	Symbol	Conditions	Ratings			Unit
			min	typ	max	
Circuit current	I_{CC1}	During drive	6	10	14	mA
	I_{CC2}	During lock protection	6	10	14	mA
6VREG voltage	6VREG	$I_{6VREG} = 5\text{mA}$	5.80	6.0	6.15	V
HB voltage	V_{HB}	$I_{HB} = 5\text{mA}$	1.05	1.22	1.35	V
VOVER voltage	V_{VOVER}	$I_{VOVER} = 1\text{mA}$	12.0	12.8	13.6	V
CPWM-H level voltage	V_{CRH}		4.35	4.55	4.75	V
CPWM-L level voltage	V_{CRL}		1.45	1.65	1.85	V
CPWM oscillation frequency	FPWM	$C = 100\text{pF}$	18	25	32	kHz
CT pin H level voltage	V_{CTH}		3.4	3.6	3.8	V
CT pin L level voltage	V_{CTL}		1.4	1.6	1.8	V
ICT pin charge current	I_{CT1}	$V_{CT} = 1.2\text{V}$	1.6	2.0	2.5	μA
ICT pin discharge current	I_{CT2}	$V_{CT} = 4.0\text{V}$	0.16	0.20	0.28	μA
ICT charge/discharge current ratio	RCT	I_{CT1}/I_{CT2}	8	10	12	deg
OUT-N output voltage	V_{ON}	$I_O = 20\text{mA}$	4	10		V
OUT-P sink current	I_{OP}		15	20		mA
Hall input sensitivity	VHN	Zero peak value (including offset and hysteresis)		10	20	mV
RD/FG output pin L voltage	V_{RD}/V_{FG}	$I_{RD}/I_{FG} = 5\text{mA}$		0.15	0.3	V
RD/FG output pin leak current	I_{RDL}/I_{FGL}	$V_{RD}/V_{FG} = 16\text{V}$			30	μA

LB11967V

Package Dimensions

unit : mm (typ)
3179C

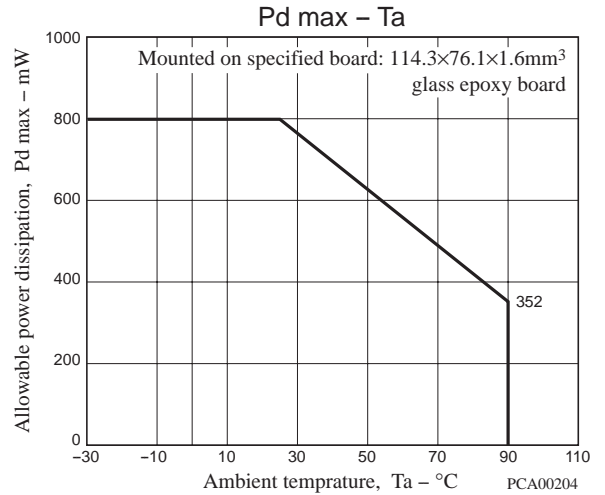
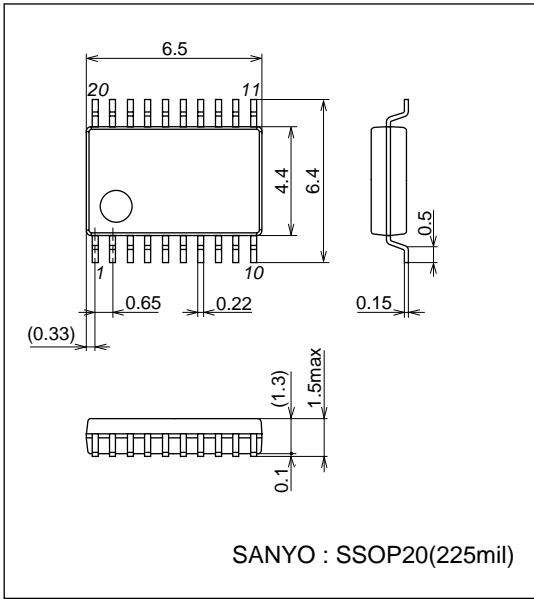

Pin Assignment

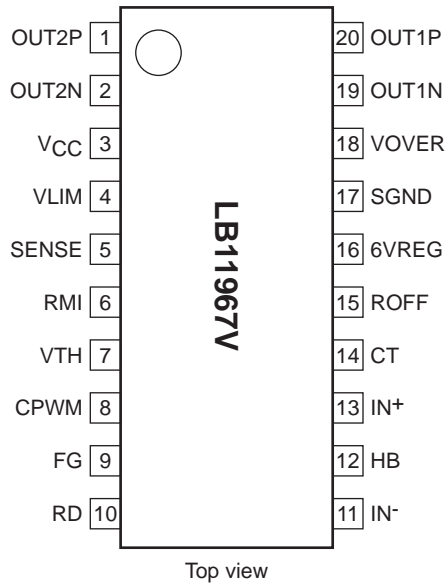

Truth Table

During full-speed rotation

IN ⁻	IN ⁺	CT	OUT1P	OUT1N	OUT2P	OUT2N	FG	RD	Mode
H	L	L	L	L	OFF	H	L	L	OUT1 → 2 drive
L	H		OFF	H	L	L	OFF		OUT2 → 1 drive
H	L	H	OFF	L	OFF	H	L	OFF	Lock protection
L	H		OFF	H	OFF	L	OFF		

VTH	CPWM	IN ⁻	IN ⁺	OUT1P	OUT1N	OUT2P	OUT2N	Mode
L	H	H	L	L	L	OFF	H	OUT1 → 2 drive
		L	H	OFF	H	L	L	OUT2 → 1 drive
H	L	H	L	OFF	L	OFF	H	During rotation Regeneration in lower Tr
		L	H	OFF	H	OFF	L	

Block Diagram

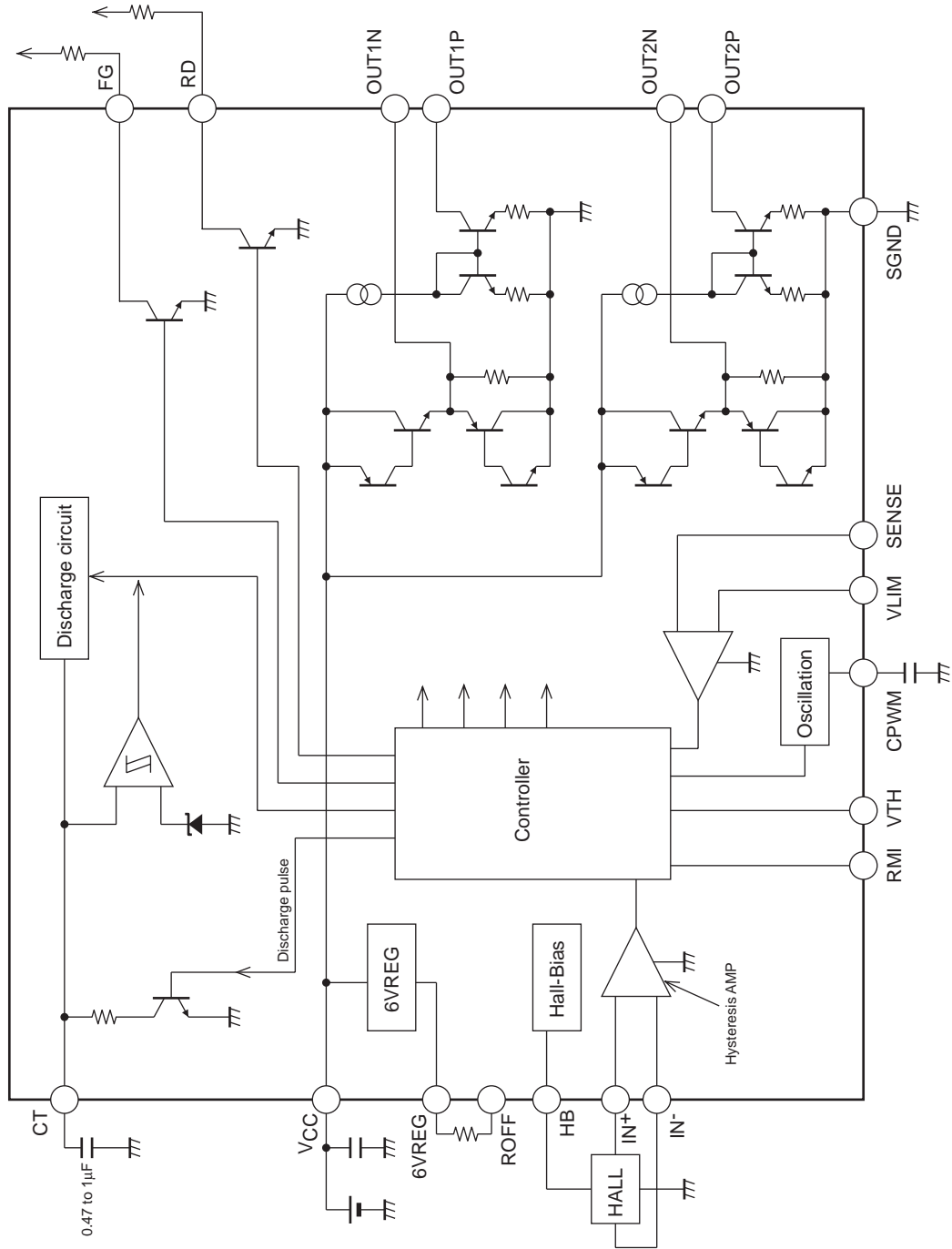

LB11967V

Sample Application Circuit 1 (12V)

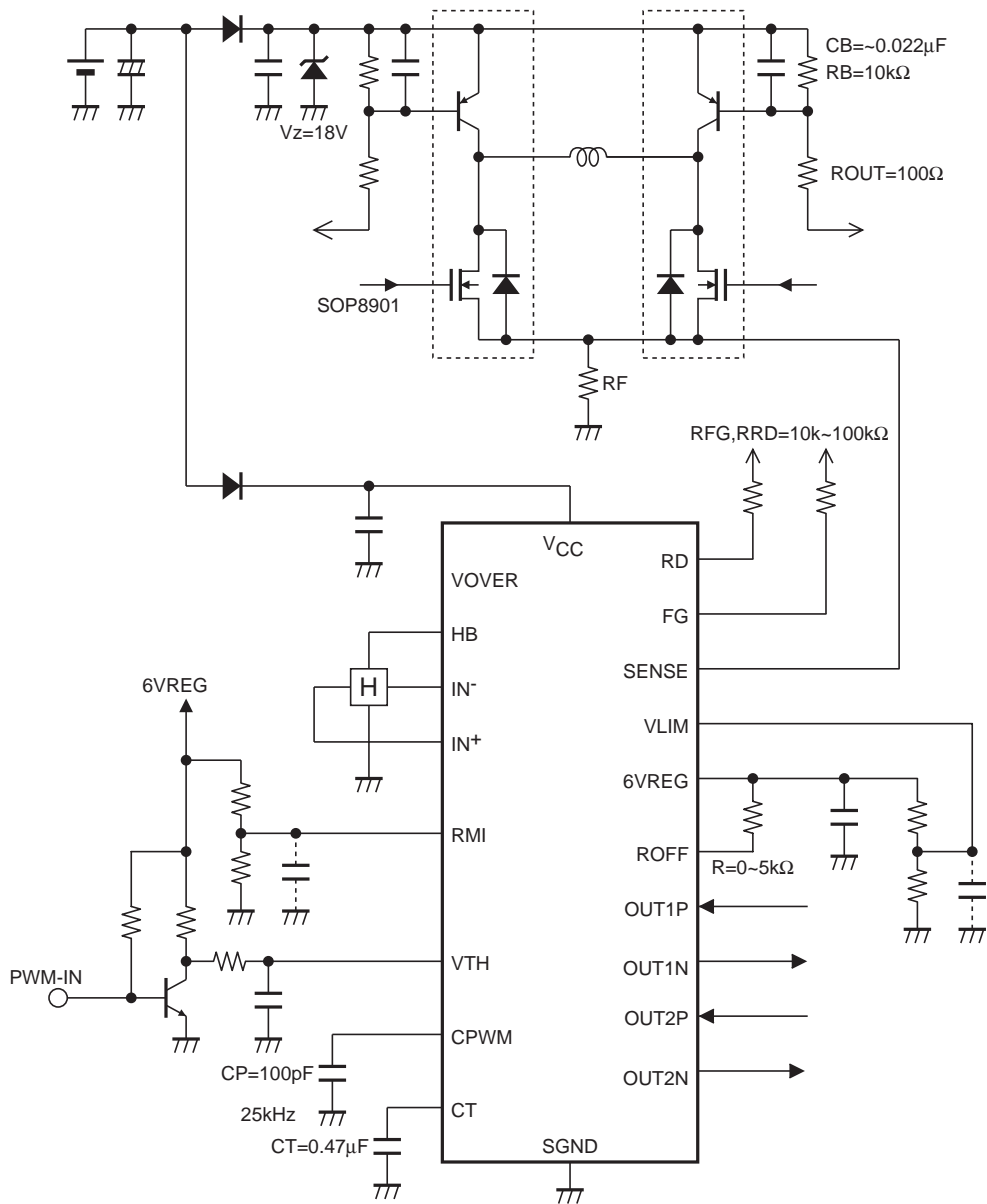

LB11967V

Sample Application Circuit 2 (24V, 48V)

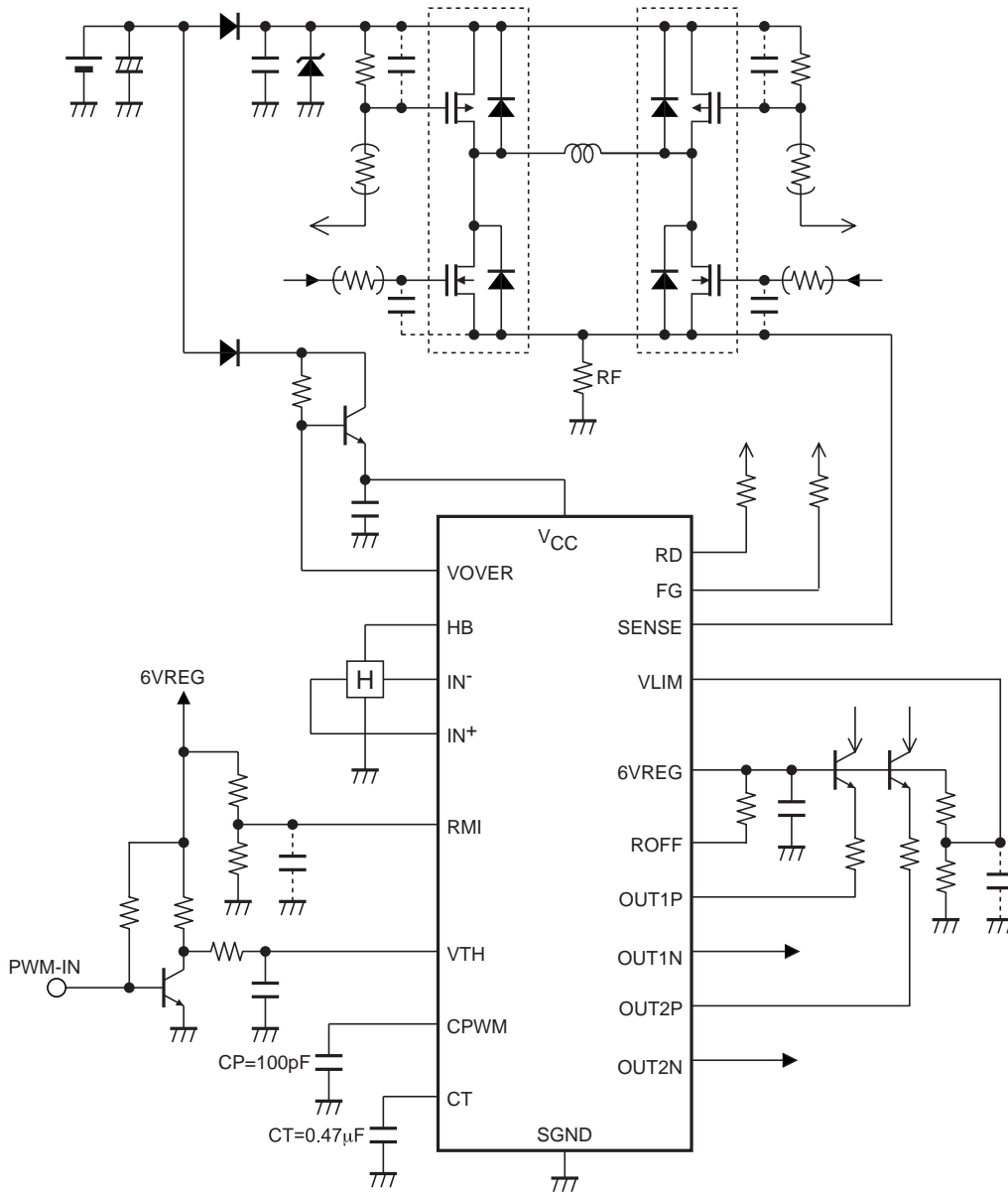

- *1. <Power supply-GND wiring>
SGND is connected to the control circuit power supply system.
- *2. <Power stabilization capacitor for regeneration>
For the CM capacitor that is a power stabilization capacitor for PWM drive and for absorption of kick-back, the capacitance uses 0.1 μ F or more. In this IC, the lower Transistor performs current regeneration by means of switching of upper Transistor. Connect CM between V_{CC} and GND with the thick pattern and along the shortest route.
- *3. <Zener diode to stabilize power supply for regeneration>
Be sure to use the zener diode if kick-back causes excessive increase of the supply voltage because such increase damages IC.
- *4. <Hall input>
Wiring need to be short to prevent carrying of the noise. If the noise is carried, insert a capacitor between IN+ and IN-. The Hall input circuit is a comparator having a hysteresis of 20mV. It is recommended that the Hall input level is more than three times (60mVp-p) this hysteresis.
- *5. <Capacitor to set the PWM oscillation frequency>
With CP = 100pF, oscillation occurs at f = 25kHz and provides the basic frequency of PWM.
- *6. <RD output>
This is the open collector output, which outputs “L” during rotation and “H” at stop. This output is left open when not used.
- *7. <FG output>
This is the open collector output, which can detect the rotation speed using the FG output according to the phase shift. This output is left open when not used.
- *8. <HB pin>
This is a Hall element bias pin, that is, the constant-voltage output pin.
- *9. <RMI pin>
This is the minimum speed setting pin, which is pulled up with 6VREG when not used.
When IC power may possibly be turned OFF first when the pin is used, be sure to insert a current limiting resistor to prevent inflow of the large current. (The same applies to the VTH pin.)
- *10. <ROFF pin>
This pin sets the soft switching time to cut the reactive current before phase change and is connected to 6VREG when not used.
- *11. <VLIM pin>
This pin activates the current limiter when the SENSE pin voltage is higher than the VLIM pin voltage and is connected to 6VREG when not used.
- *12. <SENSE pin>
This is connected to GND when not used.
- *13. <VOVER pin>
This is a pin for constant-voltage bias and should be used for application of 24V and 48V. (Refer to the sample application circuit.) Be sure to use the current limiting resistor. This is left open when not used.

Control Timing Chart

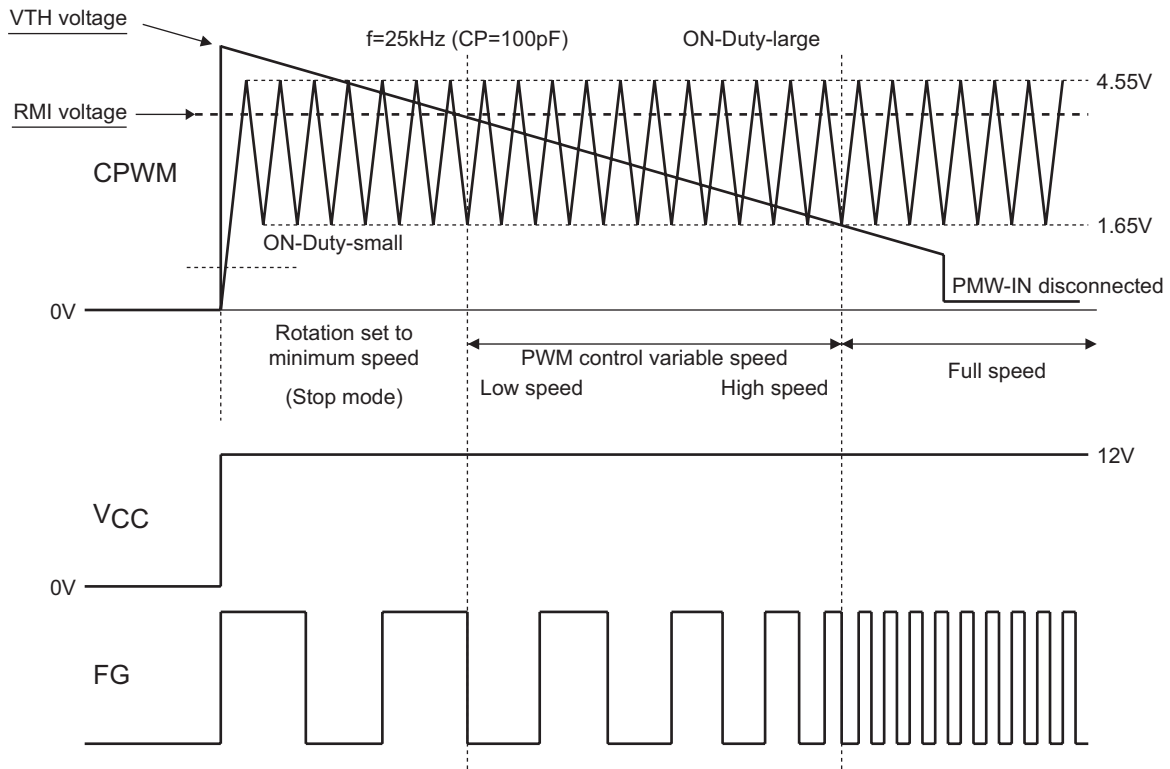

(1) Minimum speed setting (stop) mode

PWM-IN input is filtered to generate the VTH voltage. At low speed, the fan rotates with the minimum speed set with RMI pin during low speed. If the minimum speed is not set (RMI = 6VREG), the fan stops.

(2) Low↔High speed mode

PWM control is made through comparison of oscillation and VTH voltages with CPWM changing between 1.6V↔4.6V.

When the VTH voltage is lower, the IC switches to drive mode. When the VTH voltage is higher, the p-channel FET is turned off and coil current is regenerated through the low-side FET. Therefore, as the VTH voltage lowers, the output ON-DUTY increases, increasing the coil current and raising the motor speed.

The rotation speed is fed back by the FG output.

(3) Full speed mode

The full-speed mode becomes effective with the VTH voltage of 1.65V or less. (VTH must be equal to GND when the speed control is not to be made.)

(4) PWM-IN input disconnection mode

When the PWM-IN input pin is disconnected, VTH becomes 1.65V or less and the output enables full drive at 100%. The fan runs at full speed. (Refer to the sample application circuit.)

- SANYO Semiconductor Co.,Ltd. assumes no responsibility for equipment failures that result from using products at values that exceed, even momentarily, rated values (such as maximum ratings, operating condition ranges, or other parameters) listed in products specifications of any and all SANYO Semiconductor Co.,Ltd. products described or contained herein.
- SANYO Semiconductor Co.,Ltd. strives to supply high-quality high-reliability products, however, any and all semiconductor products fail or malfunction with some probability. It is possible that these probabilistic failures or malfunction could give rise to accidents or events that could endanger human lives, trouble that could give rise to smoke or fire, or accidents that could cause damage to other property. When designing equipment, adopt safety measures so that these kinds of accidents or events cannot occur. Such measures include but are not limited to protective circuits and error prevention circuits for safe design, redundant design, and structural design.
- In the event that any or all SANYO Semiconductor Co.,Ltd. products described or contained herein are controlled under any of applicable local export control laws and regulations, such products may require the export license from the authorities concerned in accordance with the above law.
- No part of this publication may be reproduced or transmitted in any form or by any means, electronic or mechanical, including photocopying and recording, or any information storage or retrieval system, or otherwise, without the prior written consent of SANYO Semiconductor Co.,Ltd.
- Any and all information described or contained herein are subject to change without notice due to product/technology improvement, etc. When designing equipment, refer to the "Delivery Specification" for the SANYO Semiconductor Co.,Ltd. product that you intend to use.
- Information (including circuit diagrams and circuit parameters) herein is for example only; it is not guaranteed for volume production.
- Upon using the technical information or products described herein, neither warranty nor license shall be granted with regard to intellectual property rights or any other rights of SANYO Semiconductor Co.,Ltd. or any third party. SANYO Semiconductor Co.,Ltd. shall not be liable for any claim or suits with regard to a third party's intellectual property rights which has resulted from the use of the technical information and products mentioned above.

This catalog provides information as of June, 2010. Specifications and information herein are subject to change without notice.