

POSITIVE VOLTAGE REGULATORS

- OUTPUT CURRENT UP TO 1.5A
- OUTPUT VOLTAGES OF 5 ; 6 ; 8 ; 8.5 ; 12 ; 15 ; 18 ; 20 ; 24V
- THERMAL OVERLOAD PROTECTION
- SHORT CIRCUIT PROTECTION
- OUTPUT TRANSISTOR SOA PROTECTION

DESCRIPTION

The L7800 series of three-terminal positive regulator is available in TO-220 and TO-3 packages and with several fixed output voltages making it useful in a wide range of applications. These regulators can provide local on-card regulation, eliminating the distribution problems associated with single point regulation. Each type employs internal current limiting, thermal shut-down and safe area protection, making it essentially indestructible. If adequate heat sinking is provided, they can deliver over 1A output current. Although designed primarily as fixed voltage regulators, these devices can be used with external components to obtain adjustable voltages and currents.

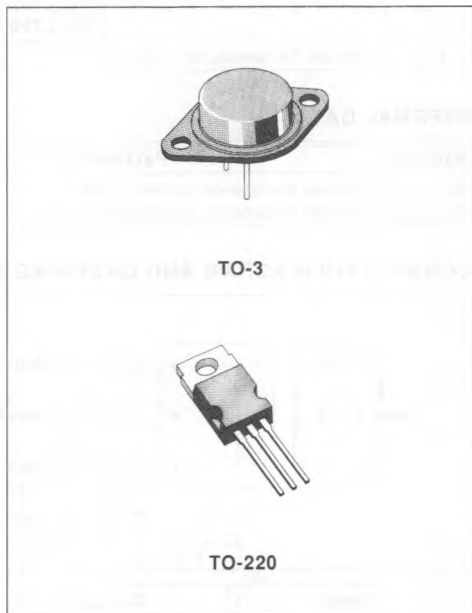

BLOCK DIAGRAM

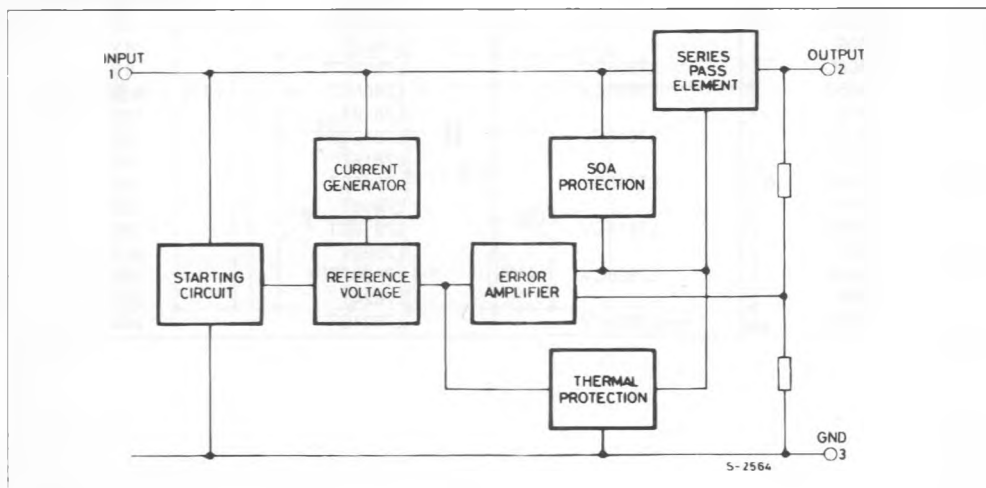

ABSOLUTE MAXIMUM RATINGS

Symbol	Parameter	Value	Unit
V_i	DC Input Voltage (for $V_o = 5$ to 18V) (for $V_o = 20, 24V$)	35 40	V V
I_o	Output Current	Internally limited	
P_{tot}	Power Dissipation	Internally limited	
T_{op}	Operating Junction Temperature (for L7800) (for L7800C)	- 55 to + 150 0 to + 150	°C °C
T_{stg}	Storage Temperature	- 65 to + 150	°C

THERMAL DATA

Symbol	Parameter		TO-220	TO-3	Unit
$R_{th\ j-case}$	Thermal Resistance Junction-case	Max	3	4	°C/W
$R_{th\ j-amb}$	Thermal Resistance Junction-ambient	Max	50	35	°C/W

CONNECTION DIAGRAM AND ORDERING NUMBERS (top view)

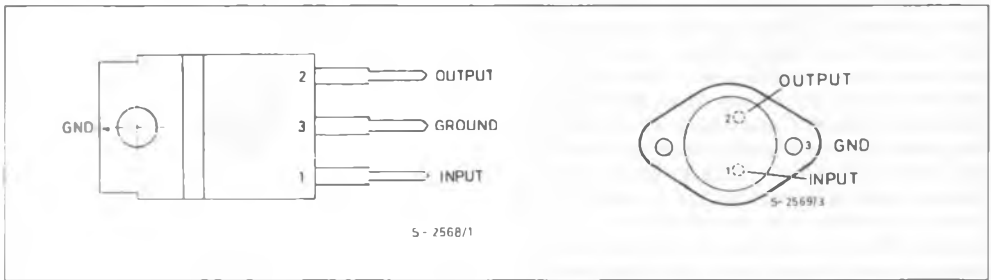

Type	TO-220	TO-3	Output Voltage
L7805		L7805T	5V
L7805C	L7805CV	L7805CT	5V
L7806		L7806T	6V
L7806C	L7806CV	L7806CT	6V
L7808		L7808T	8V
L7808C	L7808CV	L7808CT	8V
L7885C	L7885CV	L7885CT	8.5V
L7812		L7812T	12V
L7812C	L7812CV	L7812CT	12V
L7815		L7815T	15V
L7815C	L7815CV	L7815CT	15V
L7818		L7818T	18V
L7818C	L7818CV	L7818CT	18V
L7820		L7820T	20V
L7820C	L7820CV	L7820CT	20V
L7824		L7824T	24V
L7824C	L7824CV	L7824CT	24V

APPLICATION CIRCUIT

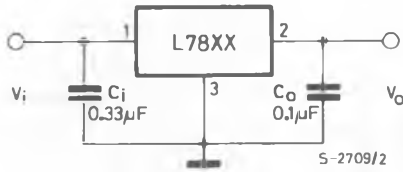

SCHEMATIC DIAGRAM

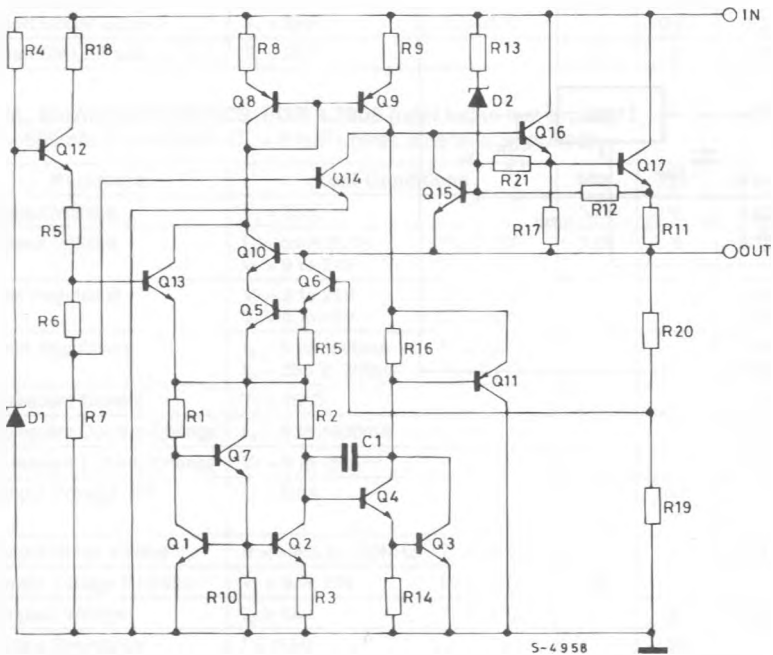

TEST CIRCUITS

Figure 1 : DC Parameters.

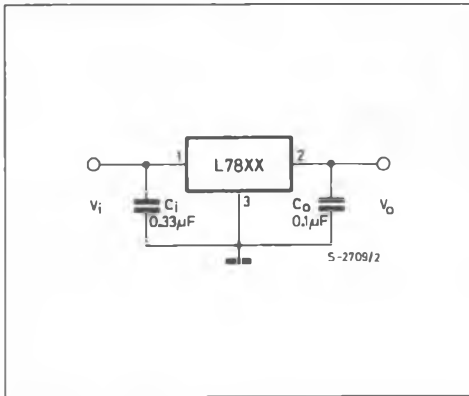

Figure 2 : Load Regulation.

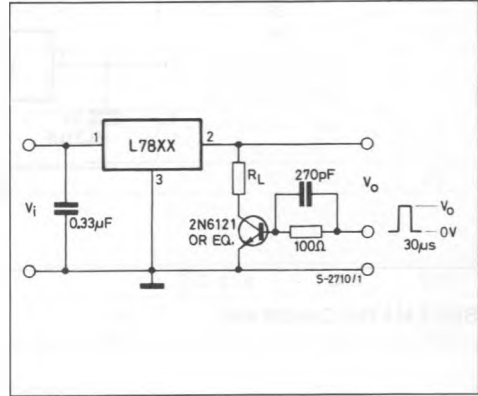
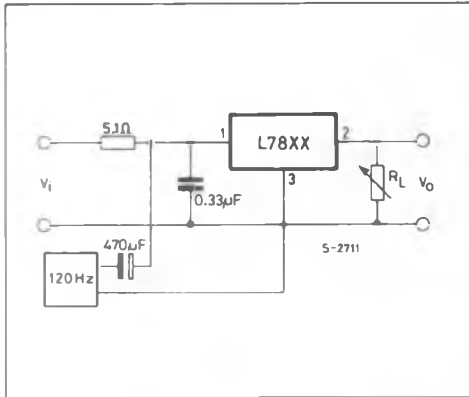

Figure 3 : Ripple Rejection.



ELECTRICAL CHARACTERISTICS FOR L7805 (refer to the test circuits, $T_j = -55$ to 150°C
 $V_i = 10\text{V}$, $I_o = 500\text{mA}$, $C_i = 0.33\mu\text{F}$, $C_o = 0.1\mu\text{F}$ unless otherwise specified)

Symbol	Parameter	Test Conditions	Min.	Typ.	Max.	Unit
V_o	Output Voltage	$T_j = 25^\circ\text{C}$	4.8	5	5.2	V
V_o	Output Voltage	$I_o = 5\text{mA to } 1\text{A}$ $V_i = 8 \text{ to } 20\text{V}$	4.65	5	5.35	V
ΔV_o^*	Line Regulation	$V_i = 7 \text{ to } 25\text{V}$ $V_i = 8 \text{ to } 12\text{V}$		3 1	50 25	mV mV
ΔV_o^*	Load Regulation	$I_o = 5 \text{ to } 1500\text{mA}$ $I_o = 250 \text{ to } 750\text{mA}$			100 25	mV mV
I_d	Quiescent Current	$T_j = 25^\circ\text{C}$			6	mA
ΔI_d	Quiescent Current Change	$I_o = 5 \text{ to } 1000\text{mA}$			0.5	mA
ΔI_d	Quiescent Current Drift	$V_i = 8 \text{ to } 25\text{V}$			0.8	mA
$\frac{\Delta V_o}{\Delta T}$	Output Voltage Drift	$I_o = 5\text{mA}$		0.6		mV/ $^\circ\text{C}$
e_N	Output Noise Voltage	$B = 10\text{Hz to } 100\text{KHz}$ $T_j = 25^\circ\text{C}$			40	$\mu\text{V}/V_o$
SVR	Supply Voltage Rejection	$V_i = 8 \text{ to } 18\text{V}$ $f = 120\text{Hz}$	68			dB
V_d	Dropout Voltage	$I_o = 1\text{A}$ $T_j = 25^\circ\text{C}$		2	2.5	V
R_o	Output Resistance	$f = 1\text{KHz}$		17		m Ω
I_{sc}	Short Circuit Current	$V_i = 35\text{V}$ $T_j = 25^\circ\text{C}$		0.75	1.2	A
I_{scp}	Short Circuit Peak Current	$T_j = 25^\circ\text{C}$	1.3	2.2	3.3	A

ELECTRICAL CHARACTERISTICS FOR L7806 (refer to the test circuits, $T_j = -55$ to 150°C
 $V_i = 11\text{V}$, $I_o = 500\text{mA}$, $C_i = 0.33\mu\text{F}$, $C_o = 0.1\mu\text{F}$ unless otherwise specified)

Symbol	Parameter	Test Conditions	Min.	Typ.	Max.	Unit
V_o	Output Voltage	$T_j = 25^\circ\text{C}$	5.75	6	6.25	V
V_o	Output Voltage	$I_o = 5\text{mA to } 1\text{A}$ $V_i = 9 \text{ to } 21\text{V}$	5.65	6	6.35	V
ΔV_o^*	Line Regulation	$V_i = 8 \text{ to } 25\text{V}$ $V_i = 9 \text{ to } 13\text{V}$			60 30	mV mV
ΔV_o^*	Load Regulation	$I_o = 5 \text{ to } 1500\text{mA}$ $I_o = 250 \text{ to } 750\text{mA}$			100 30	mV mV
I_d	Quiescent Current	$T_j = 25^\circ\text{C}$			6	mA
ΔI_d	Quiescent Current Change	$I_o = 5 \text{ to } 1000\text{mA}$			0.5	mA
ΔI_d	Quiescent Current Drift	$V_i = 9 \text{ to } 25\text{V}$			0.8	mA
$\frac{\Delta V_o}{\Delta T}$	Output Voltage Drift	$I_o = 5\text{mA}$		0.7		mV/ $^\circ\text{C}$
e_N	Output Noise Voltage	$B = 10\text{Hz to } 100\text{KHz}$ $T_j = 25^\circ\text{C}$			40	$\mu\text{V}/V_o$
SVR	Supply Voltage Rejection	$V_i = 9 \text{ to } 19\text{V}$ $f = 120\text{Hz}$	65			dB
V_d	Dropout Voltage	$I_o = 1\text{A}$ $T_j = 25^\circ\text{C}$		2	2.5	V
R_o	Output Resistance	$f = 1\text{KHz}$		19		m Ω
I_{sc}	Short Circuit Current	$V_i = 35\text{V}$ $T_j = 25^\circ\text{C}$		0.75	1.2	A
I_{scp}	Short Circuit Peak Current	$T_j = 25^\circ\text{C}$	1.3	2.2	3.3	A

* Load and line regulation are specified at constant junction temperature. Changes in V_o due to heating effects must be taken into account separately. Pulse testing with low duty cycle is used.

L7800 SERIES

ELECTRICAL CHARACTERISTICS FOR L7808 (refer to the test circuits, $T_j = -55$ to 150°C
 $V_i = 14\text{V}$, $I_o = 500\text{mA}$, $C_i = 0.33\mu\text{F}$, $C_o = 0.1\mu\text{F}$ unless otherwise specified)

Symbol	Parameter	Test Conditions	Min.	Typ.	Max.	Unit
V_o	Output Voltage	$T_j = 25^\circ\text{C}$	7.7	8	8.3	V
V_o	Output Voltage	$I_o = 5\text{mA to } 1\text{A}$ $V_i = 11.5 \text{ to } 23\text{V}$ $P_o \leq 15\text{W}$	7.6	8	8.4	V
ΔV_o^*	Line Regulation	$V_i = 10.5 \text{ to } 25\text{V}$ $V_i = 11 \text{ to } 17\text{V}$ $T_j = 25^\circ\text{C}$ $T_j = 25^\circ\text{C}$			80 40	mV mV
ΔV_o^*	Load Regulation	$I_o = 5 \text{ to } 1500\text{mA}$ $I_o = 250 \text{ to } 750\text{mA}$ $T_j = 25^\circ\text{C}$ $T_j = 25^\circ\text{C}$			100 40	mV mV
I_d	Quiescent Current	$T_j = 25^\circ\text{C}$			6	mA
ΔI_d	Quiescent Current Change	$I_o = 5 \text{ to } 1000\text{mA}$			0.5	mA
ΔI_d	Quiescent Current Change	$V_i = 11.5 \text{ to } 25\text{V}$			0.8	mA
$\frac{\Delta V_o}{\Delta T}$	Output Voltage Drift	$I_o = 5\text{mA}$		1		mV/ $^\circ\text{C}$
e_N	Output Noise Voltage	$B = 10\text{Hz to } 100\text{KHz}$ $T_j = 25^\circ\text{C}$			40	$\mu\text{V}/V_o$
SVR	Supply Voltage Rejection	$V_i = 11.5 \text{ to } 21.5\text{V}$ $f = 120\text{Hz}$	62			dB
V_d	Dropout Voltage	$I_o = 1\text{A}$ $T_j = 25^\circ\text{C}$		2	2.5	V
R_o	Output Resistance	$f = 1\text{KHz}$		16		m Ω
I_{sc}	Short Circuit Current	$V_i = 35\text{V}$ $T_j = 25^\circ\text{C}$		0.75	1.2	A
I_{scp}	Short Circuit Peak Current	$T_j = 25^\circ\text{C}$	1.3	2.2	3.3	A

ELECTRICAL CHARACTERISTICS FOR L7812 (refer to the test circuits, $T_j = -55$ to 150°C
 $V_i = 19\text{V}$, $I_o = 500\text{mA}$, $C_i = 0.33\mu\text{F}$, $C_o = 0.1\mu\text{F}$ unless otherwise specified)

Symbol	Parameter	Test Conditions	Min.	Typ.	Max.	Unit
V_o	Output Voltage	$T_j = 25^\circ\text{C}$	11.5	12	12.5	V
V_o	Output Voltage	$I_o = 5\text{mA to } 1\text{A}$ $V_i = 15.5 \text{ to } 27\text{V}$ $P_o \leq 15\text{W}$	11.4	12	12.6	V
ΔV_o^*	Line Regulation	$V_i = 14.5 \text{ to } 30\text{V}$ $V_i = 16 \text{ to } 22\text{V}$ $T_j = 25^\circ\text{C}$ $T_j = 25^\circ\text{C}$			120 60	mV mV
ΔV_o^*	Load Regulation	$I_o = 5 \text{ to } 1500\text{mA}$ $I_o = 250 \text{ to } 750\text{mA}$ $T_j = 25^\circ\text{C}$ $T_j = 25^\circ\text{C}$			120 60	mV mV
I_d	Quiescent Current	$T_j = 25^\circ\text{C}$			6	mA
ΔI_d	Quiescent Current Change	$I_o = 5 \text{ to } 1000\text{mA}$			0.5	mA
ΔI_d	Quiescent Current Change	$V_i = 15 \text{ to } 30\text{V}$			0.8	mA
$\frac{\Delta V_o}{\Delta T}$	Output Voltage Drift	$I_o = 5\text{mA}$		1.5		mV/ $^\circ\text{C}$
e_N	Output Noise Voltage	$B = 10\text{Hz to } 100\text{KHz}$ $T_j = 25^\circ\text{C}$			40	$\mu\text{V}/V_o$
SVR	Supply Voltage Rejection	$V_i = 15 \text{ to } 25\text{V}$ $f = 120\text{Hz}$	61			dB
V_d	Dropout Voltage	$I_o = 1\text{A}$ $T_j = 25^\circ\text{C}$		2	2.5	V
R_o	Output Resistance	$f = 1\text{KHz}$		18		m Ω
I_{sc}	Short Circuit Current	$V_i = 35\text{V}$ $T_j = 25^\circ\text{C}$		0.75	1.2	A
I_{scp}	Short Circuit Peak Current	$T_j = 25^\circ\text{C}$	1.3	2.2	3.3	A

* Load and line regulation are specified at constant junction temperature. Changes in V_o due to heating effects must be taken into account separately. Pulse testing with low duty cycle is used.

ELECTRICAL CHARACTERISTICS FOR L7815 (refer to the test circuits, $T_j = -55$ to 150°C
 $V_i = 23\text{V}$, $I_o = 500\text{mA}$, $C_i = 0.33\mu\text{F}$, $C_o = 0.1\mu\text{F}$ unless otherwise specified)

Symbol	Parameter	Test Conditions	Min.	Typ.	Max.	Unit
V_o	Output Voltage	$T_j = 25^\circ\text{C}$	14.4	15	15.6	V
V_o	Output Voltage	$I_o = 5\text{mA to } 1\text{A}$ $P_o \leq 15\text{W}$ $V_i = 18.5$ to 30V	14.25	15	15.75	V
ΔV_o^*	Line Regulation	$V_i = 17.5$ to 30V $T_j = 25^\circ\text{C}$ $V_i = 20$ to 26V $T_j = 25^\circ\text{C}$			150 75	mV mV
ΔV_o^*	Load Regulation	$I_o = 5$ to 1500mA $T_j = 25^\circ\text{C}$ $I_o = 250$ to 750mA $T_j = 25^\circ\text{C}$			150 75	mV mV
I_d	Quiescent Current	$T_j = 25^\circ\text{C}$			6	mA
ΔI_d	Quiescent Current Change	$I_o = 5$ to 1000mA			0.5	mA
ΔI_d	Quiescent Current Change	$V_i = 18.5$ to 30V			0.8	mA
$\frac{\Delta V_o}{\Delta T}$	Output Voltage Drift	$I_o = 5\text{mA}$		1.8		mV/ $^\circ\text{C}$
e_N	Output Noise Voltage	$B = 10\text{Hz to } 100\text{KHz}$ $T_j = 25^\circ\text{C}$		40		$\mu\text{V}/V_o$
SVR	Supply Voltage Rejection	$V_i = 18.5$ to 28.5V $f = 120\text{Hz}$	60			dB
V_d	Dropout Voltage	$I_o = 1\text{A}$ $T_j = 25^\circ\text{C}$		2	2.5	V
R_o	Output Resistance	$f = 1\text{KHz}$		19		$\text{m}\Omega$
I_{sc}	Short Circuit Current	$V_i = 35\text{V}$ $T_j = 25^\circ\text{C}$		0.75	1.2	A
I_{scp}	Short Circuit Peak Current	$T_j = 25^\circ\text{C}$	1.3	2.2	3.3	A

ELECTRICAL CHARACTERISTICS FOR L7818 (refer to the test circuits, $T_j = -55$ to 150°C
 $V_i = 26\text{V}$, $I_o = 500\text{mA}$, $C_i = 0.33\mu\text{F}$, $C_o = 0.1\mu\text{F}$ unless otherwise specified)

Symbol	Parameter	Test Conditions	Min.	Typ.	Max.	Unit
V_o	Output Voltage	$T_j = 25^\circ\text{C}$	17.3	18	18.7	V
V_o	Output Voltage	$I_o = 5\text{mA to } 1\text{A}$ $P_o \leq 15\text{W}$ $V_i = 22$ to 33V	17.1	18	18.9	V
ΔV_o^*	Line Regulation	$V_i = 21$ to 33V $T_j = 25^\circ\text{C}$ $V_i = 24$ to 30V $T_j = 25^\circ\text{C}$			180 90	mV mV
ΔV_o^*	Load Regulation	$I_o = 5$ to 1500mA $T_j = 25^\circ\text{C}$ $I_o = 250$ to 750mA $T_j = 25^\circ\text{C}$			180 90	mV mV
I_d	Quiescent Current	$T_j = 25^\circ\text{C}$			6	mA
ΔI_d	Quiescent Current Change	$I_o = 5$ to 1000mA			0.5	mA
ΔI_d	Quiescent Current Change	$V_i = 22$ to 33V			0.8	mA
$\frac{\Delta V_o}{\Delta T}$	Output Voltage Drift	$I_o = 5\text{mA}$		2.3		mV/ $^\circ\text{C}$
e_N	Output Noise Voltage	$B = 10\text{Hz to } 100\text{KHz}$ $T_j = 25^\circ\text{C}$		40		$\mu\text{V}/V_o$
SVR	Supply Voltage Rejection	$V_i = 22$ to 32V $f = 120\text{Hz}$	59			dB
V_d	Dropout Voltage	$I_o = 1\text{A}$ $T_j = 25^\circ\text{C}$		2	2.5	V
R_o	Output Resistance	$f = 1\text{KHz}$		22		$\text{m}\Omega$
I_{sc}	Short Circuit Current	$V_i = 35\text{V}$ $T_j = 25^\circ\text{C}$		0.75	1.2	A
I_{scp}	Short Circuit Peak Current	$T_j = 25^\circ\text{C}$	1.3	2.2	3.3	A

* Load and line regulation are specified at constant junction temperature. Changes in V_o due to heating effects must be taken into account separately. Pulse testing with low duty cycle is used.

L7800 SERIES

ELECTRICAL CHARACTERISTICS FOR L7820 (refer to the test circuits, $T_j = -55$ to 150°C
 $V_i = 28\text{V}$, $I_o = 500\text{mA}$, $C_i = 0.33\mu\text{F}$, $C_o = 0.1\mu\text{F}$ unless otherwise specified)

Symbol	Parameter	Test Conditions	Min.	Typ.	Max.	Unit
V_o	Output Voltage	$T_j = 25^\circ\text{C}$	19.2	20	20.8	V
V_o	Output Voltage	$I_o = 5\text{mA to } 1\text{A}$ $V_i = 24 \text{ to } 35\text{V}$ $P_o \leq 15\text{W}$	19	20	21	V
ΔV_o^*	Line Regulation	$V_i = 22.5 \text{ to } 35\text{V}$ $V_i = 26 \text{ to } 32\text{V}$ $T_j = 25^\circ\text{C}$ $T_j = 25^\circ\text{C}$			200 100	mV mV
ΔV_o^*	Load Regulation	$I_o = 5 \text{ to } 1500\text{mA}$ $I_o = 250 \text{ to } 750\text{mA}$ $T_j = 25^\circ\text{C}$ $T_j = 25^\circ\text{C}$			200 100	mV mV
I_d	Quiescent Current	$T_j = 25^\circ\text{C}$			6	mA
ΔI_d	Quiescent Current Change	$I_o = 5 \text{ to } 1000\text{mA}$			0.5	mA
ΔI_d	Quiescent Current Change	$V_i = 24 \text{ to } 35\text{V}$			0.8	mA
$\frac{\Delta V_o}{\Delta T}$	Output Voltage Drift	$I_o = 5\text{mA}$		2.5		mV/ $^\circ\text{C}$
e_N	Output Noise Voltage	$B = 10\text{Hz to } 100\text{KHz}$ $T_j = 25^\circ\text{C}$		40		$\mu\text{V}/V_o$
SVR	Supply Voltage Rejection	$V_i = 24 \text{ to } 35\text{V}$ $f = 120\text{Hz}$	58			dB
V_d	Dropout Voltage	$I_o = 1\text{A}$ $T_j = 25^\circ\text{C}$		2	2.5	V
R_o	Output Resistance	$f = 1\text{KHz}$		24		m Ω
I_{sc}	Short Circuit Current	$V_i = 35\text{V}$ $T_j = 25^\circ\text{C}$		0.75	1.2	A
I_{scP}	Short Circuit Peak Current	$T_j = 25^\circ\text{C}$	1.3	2.2	3.3	A

ELECTRICAL CHARACTERISTICS FOR L7824 (refer to the test circuits, $T_j = -55$ to 150°C
 $V_i = 33\text{V}$, $I_o = 500\text{mA}$, $C_i = 0.33\mu\text{F}$, $C_o = 0.1\mu\text{F}$ unless otherwise specified)

Symbol	Parameter	Test Conditions	Min.	Typ.	Max.	Unit
V_o	Output Voltage	$T_j = 25^\circ\text{C}$	23	24	25	V
V_o	Output Voltage	$I_o = 5\text{mA to } 1\text{A}$ $V_i = 28 \text{ to } 38\text{V}$ $P_o \leq 15\text{W}$	22.8	24	25.2	V
ΔV_o^*	Line Regulation	$V_i = 27 \text{ to } 38\text{V}$ $V_i = 30 \text{ to } 36\text{V}$ $T_j = 25^\circ\text{C}$ $T_j = 25^\circ\text{C}$			240 120	mV mV
ΔV_o^*	Load Regulation	$I_o = 5 \text{ to } 1500\text{mA}$ $I_o = 250 \text{ to } 750\text{mA}$ $T_j = 25^\circ\text{C}$ $T_j = 25^\circ\text{C}$			240 120	mV mV
I_d	Quiescent Current	$T_j = 25^\circ\text{C}$			6	mA
ΔI_d	Quiescent Current Change	$I_o = 5 \text{ to } 1000\text{mA}$			0.5	mA
ΔI_d	Quiescent Current Change	$V_i = 28 \text{ to } 38\text{V}$			0.8	mA
$\frac{\Delta V_o}{\Delta T}$	Output Voltage Drift	$I_o = 5\text{mA}$		3		mV/ $^\circ\text{C}$
e_N	Output Noise Voltage	$B = 10\text{Hz to } 100\text{KHz}$ $T_j = 25^\circ\text{C}$		40		$\mu\text{V}/V_o$
SVR	Supply Voltage Rejection	$V_i = 28 \text{ to } 38\text{V}$ $f = 120\text{Hz}$	56			dB
V_d	Dropout Voltage	$I_o = 1\text{A}$ $T_j = 25^\circ\text{C}$		2	2.5	V
R_o	Output Resistance	$f = 1\text{KHz}$		28		m Ω
I_{sc}	Short Circuit Current	$V_i = 35\text{V}$ $T_j = 25^\circ\text{C}$		0.75	1.2	A
I_{scP}	Short Circuit Peak Current	$T_j = 25^\circ\text{C}$	1.3	2.2	3.3	A

*Load and line regulation are specified at constant junction temperature. Changes in V_o due to heating effects must be taken into account separately. Pulse testing with low duty cycle is used.

ELECTRICAL CHARACTERISTICS FOR L7805C (refer to the test circuits, $T_j = 0$ to 125°C
 $V_i = 10\text{V}$, $I_o = 500\text{mA}$, $C_i = 0.33\mu\text{F}$, $C_o = 0.1\mu\text{F}$ unless otherwise specified)

Symbol	Parameter	Test Conditions	Min.	Typ.	Max.	Unit
V_o	Output Voltage	$T_j = 25^\circ\text{C}$	4.8	5	5.2	V
V_o	Output Voltage	$I_o = 5\text{mA}$ to 1A $V_i = 7$ to 20V $P_o \leq 15\text{W}$	4.75	5	5.25	V
ΔV_o^*	Line Regulation	$V_i = 7$ to 25V $V_i = 8$ to 12V $T_j = 25^\circ\text{C}$ $T_j = 25^\circ\text{C}$		3 1	100 50	mV mV
ΔV_o^*	Load Regulation	$I_o = 5$ to 1500mA $I_o = 250$ to 750mA $T_j = 25^\circ\text{C}$ $T_j = 25^\circ\text{C}$			100 50	mV mV
I_d	Quiescent Current	$T_j = 25^\circ\text{C}$			8	mA
ΔI_d	Quiescent Current Change	$I_o = 5$ to 1000mA			0.5	mA
ΔI_d	Quiescent Current Change	$V_i = 7$ to 25V			1.3	mA
ΔV_o ΔT	Output Voltage Drift	$I_o = 5\text{mA}$		- 1.1		mV/ $^\circ\text{C}$
e_N	Output Noise Voltage	$B = 10\text{Hz}$ to 100KHz $T_j = 25^\circ\text{C}$		40		$\mu\text{V}/V_o$
SVR	Supply Voltage Rejection	$V_i = 8$ to 18V $f = 120\text{Hz}$	62			dB
V_d	Dropout Voltage	$I_o = 1\text{A}$ $T_j = 25^\circ\text{C}$		2		V
R_o	Output Resistance	$f = 1\text{KHz}$		17		$\text{m}\Omega$
I_{sc}	Short Circuit Current	$V_i = 35\text{V}$ $T_j = 25^\circ\text{C}$		750		mA
I_{scp}	Short Circuit Peak Current	$T_j = 25^\circ\text{C}$		2.2		A

ELECTRICAL CHARACTERISTICS FOR L7806C (refer to the test circuits, $T_j = 0$ to 125°C
 $V_i = 11\text{V}$, $I_o = 500\text{mA}$, $C_i = 0.33\mu\text{F}$, $C_o = 0.1\mu\text{F}$ unless otherwise specified)

Symbol	Parameter	Test Conditions	Min.	Typ.	Max.	Unit
V_o	Output Voltage	$T_j = 25^\circ\text{C}$	5.75	6	6.25	V
V_o	Output Voltage	$I_o = 5\text{mA}$ to 1A $V_i = 8$ to 21V $P_o \leq 15\text{W}$	5.7	6	6.3	V
ΔV_o^*	Line Regulation	$V_i = 8$ to 25V $V_i = 9$ to 13V $T_j = 25^\circ\text{C}$ $T_j = 25^\circ\text{C}$			120 60	mV mV
ΔV_o^*	Load Regulation	$I_o = 5$ to 1500mA $I_o = 250$ to 750mA $T_j = 25^\circ\text{C}$ $T_j = 25^\circ\text{C}$			120 60	mV mV
I_d	Quiescent Current	$T_j = 25^\circ\text{C}$			8	mA
ΔI_d	Quiescent Current Change	$I_o = 5$ to 1000mA			0.5	mA
ΔI_d	Quiescent Current Change	$V_i = 8$ to 25V			1.3	mA
ΔV_o ΔT	Output Voltage Drift	$I_o = 5\text{mA}$		- 0.8		mV/ $^\circ\text{C}$
e_N	Output Noise Voltage	$B = 10\text{Hz}$ to 100KHz $T_j = 25^\circ\text{C}$		45		$\mu\text{V}/V_o$
SVR	Supply Voltage Rejection	$V_i = 9$ to 19V $f = 120\text{Hz}$	59			dB
V_d	Dropout Voltage	$I_o = 1\text{A}$ $T_j = 25^\circ\text{C}$		2		V
R_o	Output Resistance	$f = 1\text{KHz}$		19		$\text{m}\Omega$
I_{sc}	Short Circuit Current	$V_i = 35\text{V}$ $T_j = 25^\circ\text{C}$		550		mA
I_{scp}	Short Circuit Peak Current	$T_j = 25^\circ\text{C}$		2.2		A

* Load and line regulation are specified at constant junction temperature. Changes in V_o due to heating effects must be taken into account separately. Pulse testing with low duty cycle is used.

L7800 SERIES

ELECTRICAL CHARACTERISTICS FOR L7808C (refer to the test circuits, $T_j = 0$ to 125°C $V_i = 14\text{V}$, $I_o = 500\text{mA}$, $C_i = 0.33\mu\text{F}$, $C_o = 0.1\mu\text{F}$ unless otherwise specified)

Symbol	Parameter	Test Conditions	Min.	Typ.	Max.	Unit	
V_o	Output Voltage	$T_j = 25^\circ\text{C}$	7.7	8	8.3	V	
V_o	Output Voltage	$I_o = 5\text{mA}$ to 1A $V_i = 10.5$ to 25V	$P_o \leq 15\text{W}$	7.6	8	8.4	V
ΔV_o^*	Line Regulation	$V_i = 10.5$ to 25V $V_i = 11$ to 17V	$T_j = 25^\circ\text{C}$ $T_j = 25^\circ\text{C}$		160 80	mV mV	
ΔV_o^*	Load Regulation	$I_o = 5$ to 1500mA $I_o = 250$ to 750mA	$T_j = 25^\circ\text{C}$ $T_j = 25^\circ\text{C}$		160 80	mV mV	
I_d	Quiescent Current	$T_j = 25^\circ\text{C}$			8	mA	
ΔI_d	Quiescent Current Change	$I_o = 5$ to 1000mA			0.5	mA	
ΔI_d	Quiescent Current Change	$V_i = 10.5$ to 25V			1	mA	
$\frac{\Delta V_o}{\Delta T}$	Output Voltage Drift	$I_o = 5\text{mA}$		- 0.8		mV/ $^\circ\text{C}$	
e_N	Output Noise Voltage	$B = 10\text{Hz}$ to 100KHz	$T_j = 25^\circ\text{C}$	52		$\mu\text{V}/V_o$	
SVR	Supply Voltage Rejection	$V_i = 11.5$ to 21.5V	$f = 120\text{Hz}$	56		dB	
V_d	Dropout Voltage	$I_o = 1\text{A}$	$T_j = 25^\circ\text{C}$	2		V	
R_o	Output Resistance	$f = 1\text{KHz}$		16		$\text{m}\Omega$	
I_{sc}	Short Circuit Current	$V_i = 35\text{V}$	$T_j = 25^\circ\text{C}$	450		mA	
I_{scp}	Short Circuit Peak Current	$T_j = 25^\circ\text{C}$		2.2		A	

ELECTRICAL CHARACTERISTICS FOR L7885C (refer to the test circuits, $T_j = 0$ to 125°C $V_i = 14.5\text{V}$, $I_o = 500\text{mA}$, $C_i = 0.33\mu\text{F}$, $C_o = 0.1\mu\text{F}$ unless otherwise specified)

Symbol	Parameter	Test Conditions	Min.	Typ.	Max.	Unit	
V_o	Output Voltage	$T_j = 25^\circ\text{C}$	8.2	8.5	8.8	V	
V_o	Output Voltage	$I_o = 5\text{mA}$ to 1A $V_i = 11$ to 26V	$P_o \leq 15\text{W}$	8.1	8.5	8.9	V
ΔV_o^*	Line Regulation	$V_i = 11$ to 27V $V_i = 11.5$ to 17.5V	$T_j = 25^\circ\text{C}$ $T_j = 25^\circ\text{C}$		160 80	mV mV	
ΔV_o^*	Load Regulation	$I_o = 5$ to 1500mA $I_o = 250$ to 750mA	$T_j = 25^\circ\text{C}$ $T_j = 25^\circ\text{C}$		160 80	mV mV	
I_d	Quiescent Current	$T_j = 25^\circ\text{C}$			8	mA	
ΔI_d	Quiescent Current Change	$I_o = 5$ to 1000mA			0.5	mA	
ΔI_d	Quiescent Current Change	$V_i = 11$ to 27V			1	mA	
$\frac{\Delta V_o}{\Delta T}$	Output Voltage Drift	$I_o = 5\text{mA}$		- 0.8		mV/ $^\circ\text{C}$	
e_N	Output Noise Voltage	$B = 10\text{Hz}$ to 100KHz	$T_j = 25^\circ\text{C}$	55		$\mu\text{V}/V_o$	
SVR	Supply Voltage Rejection	$V_i = 12$ to 22V	$f = 120\text{Hz}$	56		dB	
V_d	Dropout Voltage	$I_o = 1\text{A}$	$T_j = 25^\circ\text{C}$	2		V	
R_o	Output Resistance	$f = 1\text{KHz}$		16		$\text{m}\Omega$	
I_{sc}	Short Circuit Current	$V_i = 35\text{V}$	$T_j = 25^\circ\text{C}$	450		mA	
I_{scp}	Short Circuit Peak Current	$T_j = 25^\circ\text{C}$		2.2		A	

* Load and line regulation are specified at constant junction temperature. Changes in V_o due to heating effects must be taken into account separately. Pulse testing with low duty cycle is used.

ELECTRICAL CHARACTERISTICS FOR L7812C (refer to the test circuits, $T_j = 0$ to 125°C
 $V_i = 19\text{V}$, $I_o = 500\text{mA}$, $C_i = 0.33\mu\text{F}$, $C_o = 0.1\mu\text{F}$ unless otherwise specified)

Symbol	Parameter	Test Conditions	Min.	Typ.	Max.	Unit
V_o	Output Voltage	$T_j = 25^\circ\text{C}$	11.5	12	12.5	V
V_o	Output Voltage	$I_o = 5\text{mA}$ to 1A $V_i = 14.5$ to 27V $P_o \leq 15\text{W}$	11.4	12	12.6	V
ΔV_o^*	Line Regulation	$V_i = 14.5$ to 30V $V_i = 16$ to 22V $T_j = 25^\circ\text{C}$ $T_j = 25^\circ\text{C}$			240 120	mV mV
ΔV_o^*	Load Regulation	$I_o = 5$ to 1500mA $I_o = 250$ to 750mA $T_j = 25^\circ\text{C}$ $T_j = 25^\circ\text{C}$			240 120	mV mV
I_d	Quiescent Current	$T_j = 25^\circ\text{C}$			8	mA
ΔI_d	Quiescent Current Change	$I_o = 5$ to 1000mA			0.5	mA
ΔI_d	Quiescent Current Change	$V_i = 14.5$ to 30V			1	mA
$\frac{\Delta V_o}{\Delta T}$	Output Voltage Drift	$I_o = 5\text{mA}$		- 1		mV/ $^\circ\text{C}$
e_N	Output Noise Voltage	$B = 10\text{Hz}$ to 100KHz $T_j = 25^\circ\text{C}$		75		$\mu\text{V}/V_o$
SVR	Supply Voltage Rejection	$V_i = 15$ to 25V $f = 120\text{Hz}$	55			dB
V_d	Dropout Voltage	$I_o = 1\text{A}$ $T_j = 25^\circ\text{C}$		2		V
R_o	Output Resistance	$f = 1\text{KHz}$		18		m Ω
I_{sc}	Short Circuit Current	$V_i = 35\text{V}$ $T_j = 25^\circ\text{C}$		350		mA
I_{scp}	Short Circuit Peak Current	$T_j = 25^\circ\text{C}$		2.2		A

ELECTRICAL CHARACTERISTICS FOR L7815C (refer to the test circuits, $T_j = 0$ to 125°C
 $V_i = 23\text{V}$, $I_o = 500\text{mA}$, $C_i = 0.33\mu\text{F}$, $C_o = 0.1\mu\text{F}$ unless otherwise specified)

Symbol	Parameter	Test Conditions	Min.	Typ.	Max.	Unit
V_o	Output Voltage	$T_j = 25^\circ\text{C}$	14.4	15	15.6	V
V_o	Output Voltage	$I_o = 5\text{mA}$ to 1A $V_i = 17.5$ to 30V $P_o \leq 15\text{W}$	14.25	15	15.75	V
ΔV_o^*	Line Regulation	$V_i = 17.5$ to 30V $V_i = 20$ to 26V $T_j = 25^\circ\text{C}$ $T_j = 25^\circ\text{C}$			300 150	mV mV
ΔV_o^*	Load Regulation	$I_o = 5$ to 1500mA $I_o = 250$ to 750mA $T_j = 25^\circ\text{C}$ $T_j = 25^\circ\text{C}$			300 150	mV mV
I_d	Quiescent Current	$T_j = 25^\circ\text{C}$			8	mA
ΔI_d	Quiescent Current Change	$I_o = 5$ to 1000mA			0.5	mA
ΔI_d	Quiescent Current Change	$V_i = 17.5$ to 30V			1	mA
$\frac{\Delta V_o}{\Delta T}$	Output Voltage Drift	$I_o = 5\text{mA}$		- 1		mV/ $^\circ\text{C}$
e_N	Output Noise Voltage	$B = 10\text{Hz}$ to 100KHz $T_j = 25^\circ\text{C}$		90		$\mu\text{V}/V_o$
SVR	Supply Voltage Rejection	$V_i = 18.5$ to 28.5V $f = 120\text{Hz}$	54			dB
V_d	Dropout Voltage	$I_o = 1\text{A}$ $T_j = 25^\circ\text{C}$		2		V
R_o	Output Resistance	$f = 1\text{KHz}$		19		m Ω
I_{sc}	Short Circuit Current	$V_i = 35\text{V}$ $T_j = 25^\circ\text{C}$		230		mA
I_{scp}	Short Circuit Peak Current	$T_j = 25^\circ\text{C}$		2.1		A

* Load and line regulation are specified at constant junction temperature. Changes in V_o due to heating effects must be taken into account separately. Pulse testing with low duty cycle is used.

L7800 SERIES

ELECTRICAL CHARACTERISTICS FOR L7818C (refer to the test circuits, $T_j = 0$ to 125°C
 $V_i = 26\text{V}$, $I_o = 500\text{mA}$, $C_i = 0.33\mu\text{F}$, $C_o = 0.1\mu\text{F}$ unless otherwise specified)

Symbol	Parameter	Test Conditions	Min.	Typ.	Max.	Unit
V_o	Output Voltage	$T_j = 25^\circ\text{C}$	17.3	18	18.7	V
V_o	Output Voltage	$I_o = 5\text{mA}$ to 1A $V_i = 21$ to 33V $P_o \leq 15\text{W}$	17.1	18	18.9	V
ΔV_o^*	Line Regulation	$V_i = 21$ to 33V $V_i = 24$ to 30V $T_j = 25^\circ\text{C}$ $T_j = 25^\circ\text{C}$			360 180	mV mV
ΔV_o^*	Load Regulation	$I_o = 5$ to 1500mA $I_o = 250$ to 750mA $T_j = 25^\circ\text{C}$ $T_j = 25^\circ\text{C}$			360 180	mV mV
I_d	Quiescent Current	$T_j = 25^\circ\text{C}$			8	mA
ΔI_d	Quiescent Current Change	$I_o = 5$ to 1000mA			0.5	mA
ΔI_d	Quiescent Current Change	$V_i = 21$ to 33V			1	mA
$\frac{\Delta V_o}{\Delta T}$	Output Voltage Drift	$I_o = 5\text{mA}$		- 1		mV/ $^\circ\text{C}$
e_N	Output Noise Voltage	$B = 10\text{Hz}$ to 100KHz $T_j = 25^\circ\text{C}$		110		$\mu\text{V}/V_o$
SVR	Supply Voltage Rejection	$V_i = 22$ to 32V $f = 120\text{Hz}$	53			dB
V_d	Dropout Voltage	$I_o = 1\text{A}$ $T_j = 25^\circ\text{C}$		2		V
R_o	Output Resistance	$f = 1\text{KHz}$		22		$\text{m}\Omega$
I_{sc}	Short Circuit Current	$V_i = 35\text{V}$ $T_j = 25^\circ\text{C}$		200		mA
I_{scp}	Short Circuit Peak Current	$T_j = 25^\circ\text{C}$		2.1		A

ELECTRICAL CHARACTERISTICS FOR L7820C (refer to the test circuits, $T_j = 0$ to 125°C
 $V_i = 28\text{V}$, $I_o = 500\text{mA}$, $C_i = 0.33\mu\text{F}$, $C_o = 0.1\mu\text{F}$ unless otherwise specified)

Symbol	Parameter	Test Conditions	Min.	Typ.	Max.	Unit
V_o	Output Voltage	$T_j = 25^\circ\text{C}$	19.2	20	20.8	V
V_o	Output Voltage	$I_o = 5\text{mA}$ to 1A $V_i = 23$ to 35V $P_o \leq 15\text{W}$	19	20	21	V
ΔV_o^*	Line Regulation	$V_i = 22.5$ to 35V $V_i = 26$ to 32V $T_j = 25^\circ\text{C}$ $T_j = 25^\circ\text{C}$			400 200	mV mV
ΔV_o^*	Load Regulation	$I_o = 5$ to 1500mA $I_o = 250$ to 750mA $T_j = 25^\circ\text{C}$ $T_j = 25^\circ\text{C}$			400 200	mV mV
I_d	Quiescent Current	$T_j = 25^\circ\text{C}$			8	mA
ΔI_d	Quiescent Current Change	$I_o = 5$ to 1000mA			0.5	mA
ΔI_d	Quiescent Current Change	$V_i = 23$ to 35V			1	mA
$\frac{\Delta V_o}{\Delta T}$	Output Voltage Drift	$I_o = 5\text{mA}$		- 1		mV/ $^\circ\text{C}$
e_N	Output Noise Voltage	$B = 10\text{Hz}$ to 100KHz $T_j = 25^\circ\text{C}$		150		$\mu\text{V}/V_o$
SVR	Supply Voltage Rejection	$V_i = 24$ to 35V $f = 120\text{Hz}$	52			dB
V_d	Dropout Voltage	$I_o = 1\text{A}$ $T_j = 25^\circ\text{C}$		2		V
R_o	Output Resistance	$f = 1\text{KHz}$		24		$\text{m}\Omega$
I_{sc}	Short Circuit Current	$V_i = 35\text{V}$ $T_j = 25^\circ\text{C}$		180		mA
I_{scp}	Short Circuit Peak Current	$T_j = 25^\circ\text{C}$		2.2		A

* Load and line regulation are specified at constant junction temperature. Changes in V_o due to heating effects must be taken into account separately. Pulse testing with low duty cycle is used.

ELECTRICAL CHARACTERISTICS FOR L7824C (refer to the test circuits, $T_j = 0$ to 125°C
 $V_i = 33\text{V}$, $I_o = 500\text{mA}$, $C_i = 0.33\mu\text{F}$, $C_o = 0.1\mu\text{F}$ unless otherwise specified)

Symbol	Parameter	Test Conditions	Min.	Typ.	Max.	Unit
V_o	Output Voltage	$T_j = 25^\circ\text{C}$	23	24	25	V
V_o	Output Voltage	$I_o = 5\text{mA to } 1\text{A}$ $V_i = 27 \text{ to } 38\text{V}$ $P_o \leq 15\text{W}$	22.8	24	25.2	V
ΔV_o^*	Line Regulation	$V_i = 27 \text{ to } 38\text{V}$ $V_i = 30 \text{ to } 36\text{V}$ $T_j = 25^\circ\text{C}$ $T_j = 25^\circ\text{C}$			480 240	mV mV
ΔV_o^*	Load Regulation	$I_o = 5 \text{ to } 1500\text{mA}$ $I_o = 250 \text{ to } 750\text{mA}$ $T_j = 25^\circ\text{C}$ $T_j = 25^\circ\text{C}$			480 240	mV mV
I_d	Quiescent Current	$T_j = 25^\circ\text{C}$			8	mA
ΔI_d	Quiescent Current Change	$I_o = 5 \text{ to } 1000\text{mA}$			0.5	mA
ΔI_d	Quiescent Current Change	$V_i = 27 \text{ to } 38\text{V}$			1	mA
$\frac{\Delta V_o}{\Delta T}$	Output Voltage Drift	$I_o = 5\text{mA}$		- 1.5		mV/ $^\circ\text{C}$
e_N	Output Noise Voltage	$B = 10\text{Hz to } 100\text{KHz}$ $T_j = 25^\circ\text{C}$		170		$\mu\text{V}/V_o$
SVR	Supply Voltage Rejection	$V_i = 28 \text{ to } 38\text{V}$ $f = 120\text{Hz}$	50			dB
V_d	Dropout Voltage	$I_o = 1\text{A}$ $T_j = 25^\circ\text{C}$		2		V
R_o	Output Resistance	$f = 1\text{KHz}$		28		$\text{m}\Omega$
I_{sc}	Short Circuit Current	$V_i = 35\text{V}$ $T_j = 25^\circ\text{C}$		150		mA
I_{scp}	Short Circuit Peak Current	$T_j = 25^\circ\text{C}$		2.1		A

* Load and line regulation are specified at constant junction temperature. Changes in V_o due to heating effects must be taken into account separately. Pulse testing with low duty cycle is used

Figure 4 : Dropout Voltage vs. Junction Temperature.

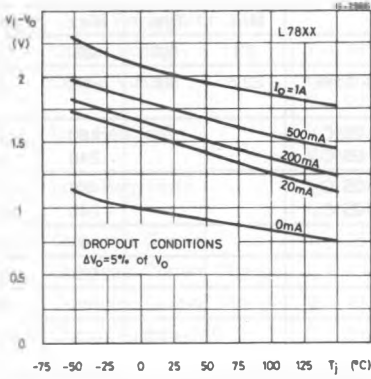

Figure 5 : Peak Output Current vs. Input/output Differential Voltage.

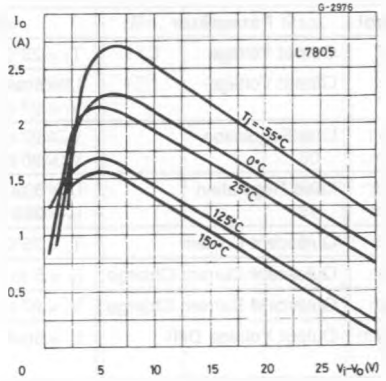

Figure 6 : Supply Voltage Rejection vs. Frequency.

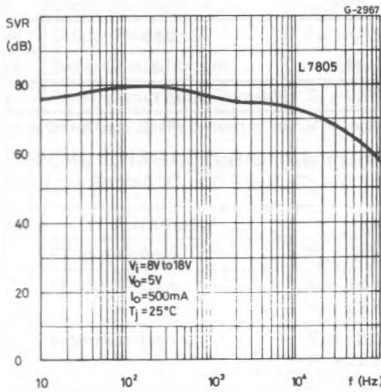

Figure 7 : Output Voltage vs. Junction Temperature.

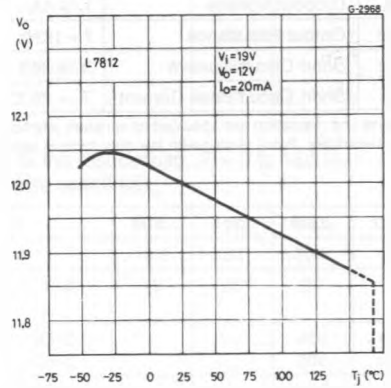

Figure 8 : Output Impedance vs. Frequency.

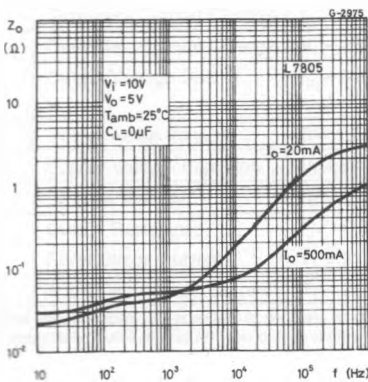

Figure 9 : Quiescent Current vs. Junction Temperature.

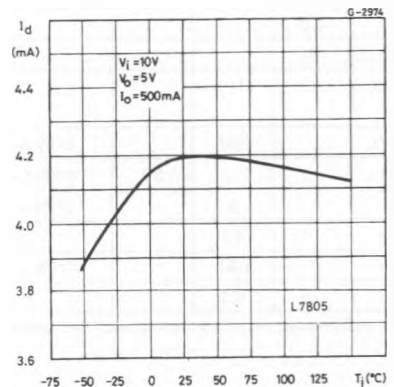

Figure 10 : Load Transient Response.

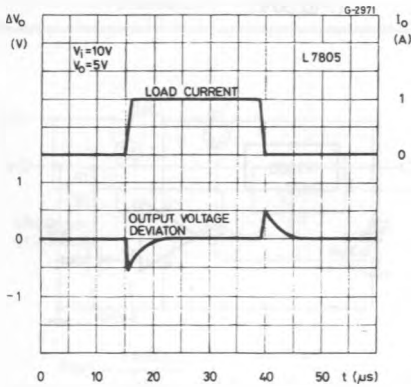

Figure 11 : Line Transient Response.

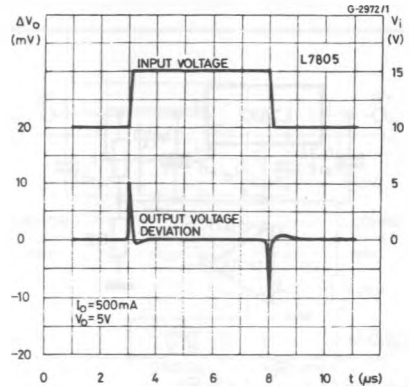

Figure 12 : Quiescent Current vs. Input Voltage.

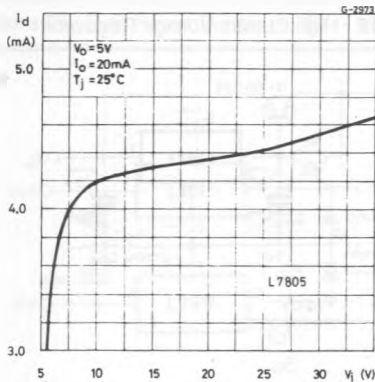

Figure 13 : Fixed Output Regulator.

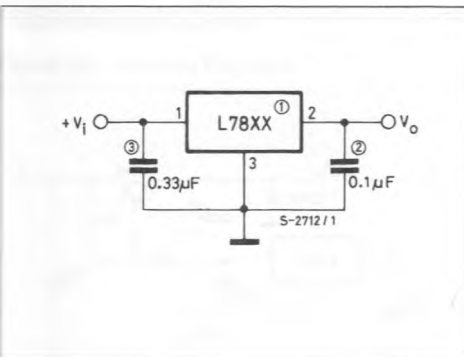
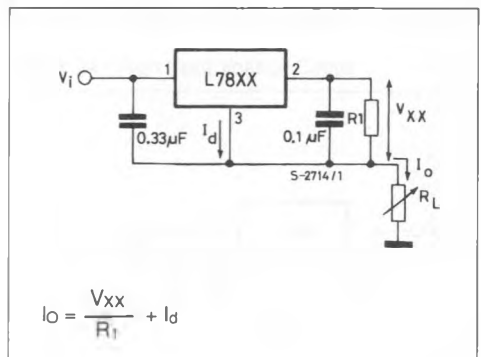

Figure 14 : Current Regulator.



- Notes :
1. To specify an output voltage, substitute voltage value for "XX"
 2. Although no output capacitor is needed for stability, it does improve transient response
 3. Required if regulator is located an appreciable distance from power supply filter.

Figure 15 : Circuit for Increasing Output Voltage.

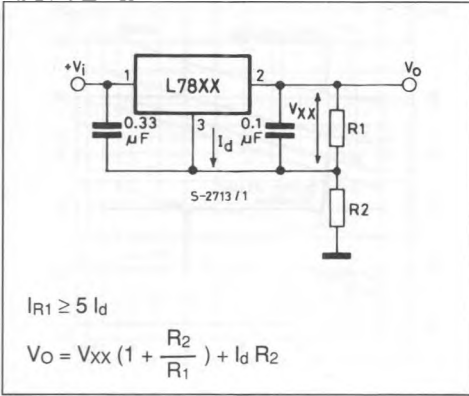

Figure 16 : Adjustable Output Regulator (7 to 30V).

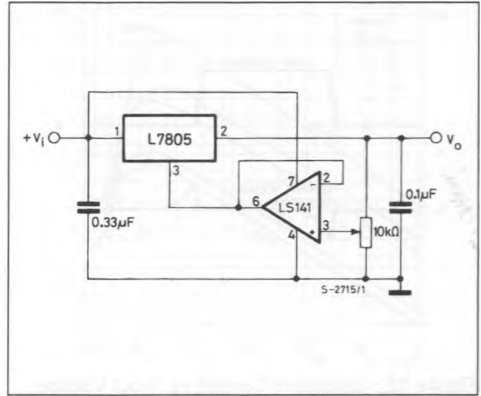

Figure 17 : 0.5 to 10V Regulator.

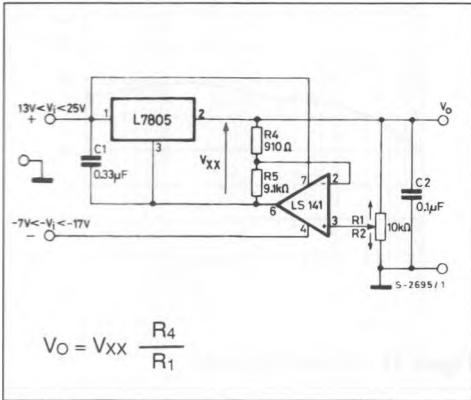

Figure 18 : High Current Voltage Regulator.

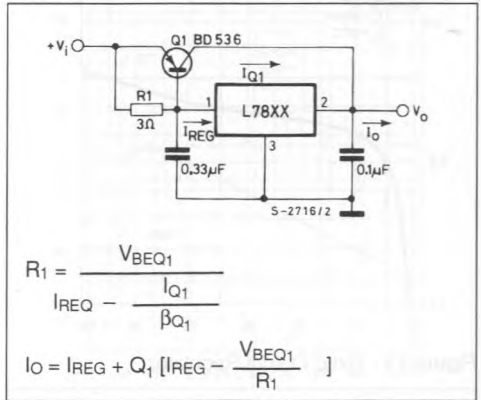

Figure 19 : High Output Current with Short Circuit Protection.

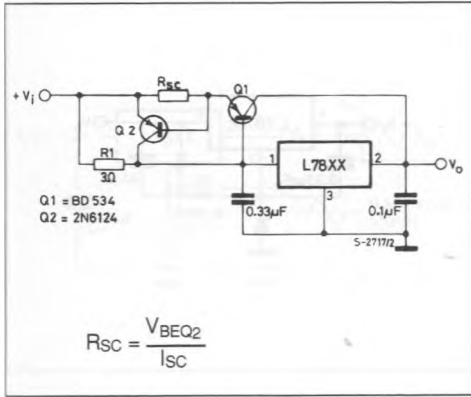

Figure 21 : Split Power Supply ($\pm 15V - 1A$).

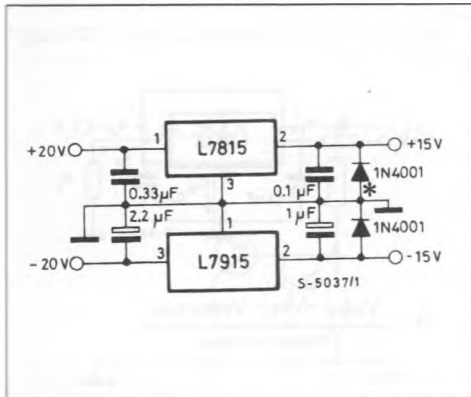

Figure 23 : Switching Regulator.

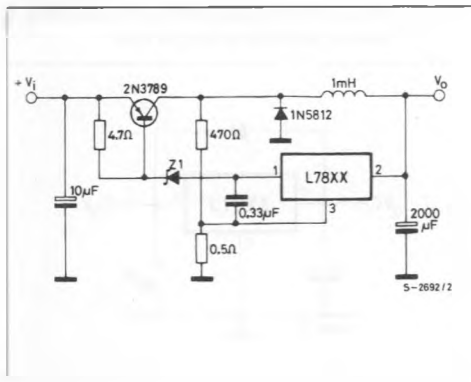

Figure 20 : Tracking Voltage Regulator.

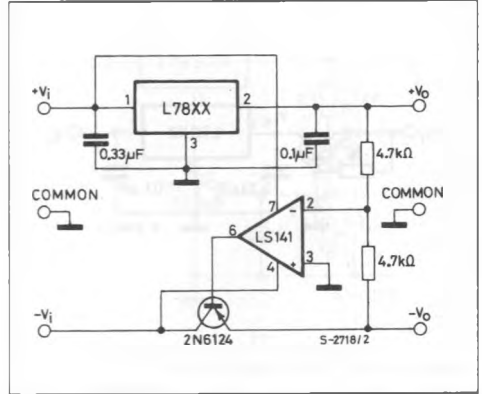

Figure 22 : Negative Output Voltage Circuit.

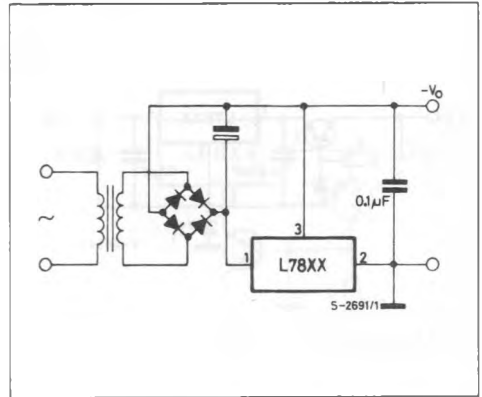

Figure 24 : High Input Voltage Circuit.

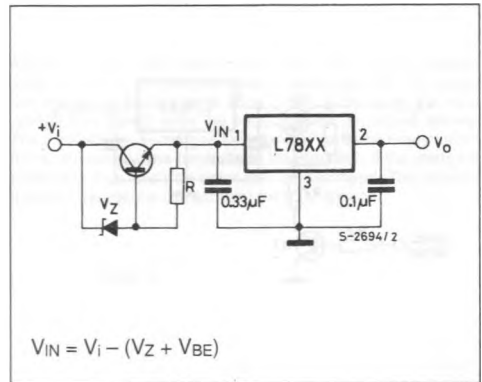

Figure 25 : High Input Voltage Circuit.

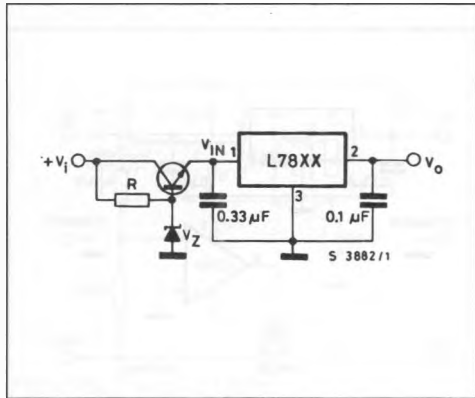

Figure 26 : High Output Voltage Regulator.

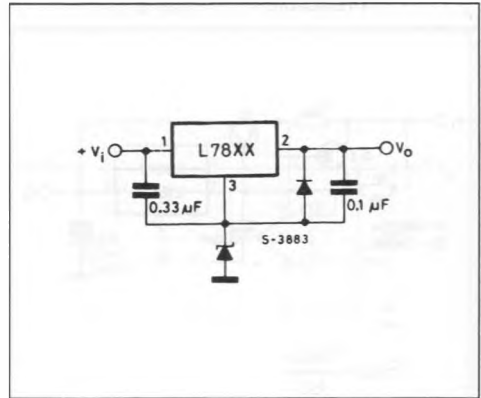

Figure 27 : High Input and Output Voltage.

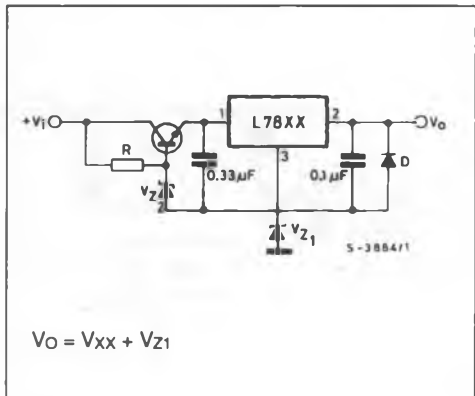

Figure 28 : Reducing Power Dissipation with Dropping Resistor.

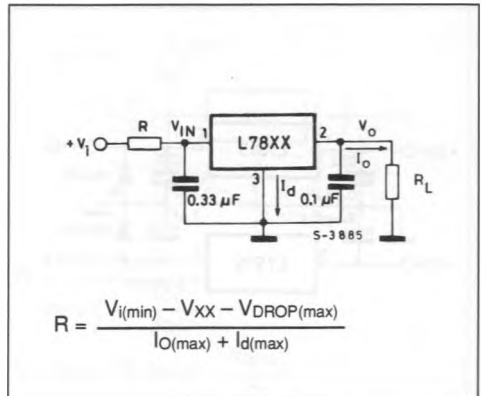

Figure 29 : Remote Shutdown.

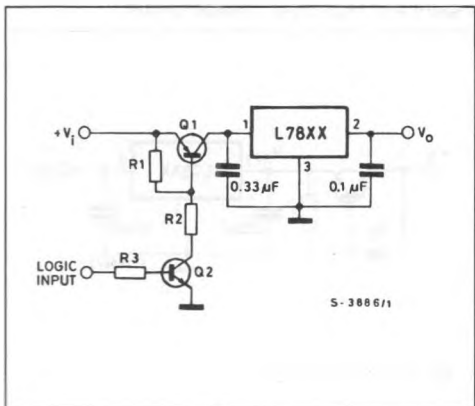
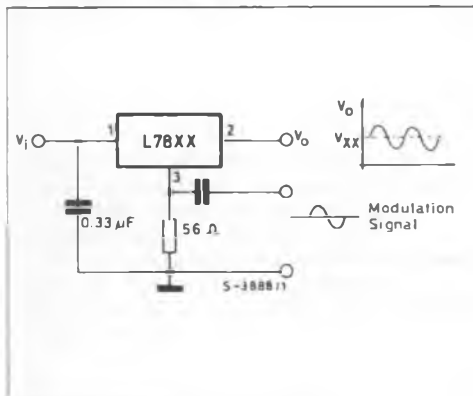
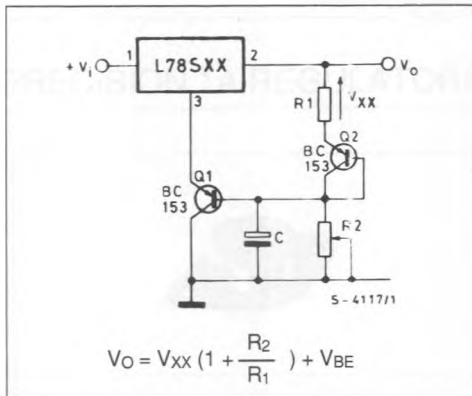

Figure 30 : Power AM Modulator (unity voltage gain, $I_o \leq 1A$).



Note : The circuit performs well up to 100KHz

Figure 31 : Adjustable Output Voltage with Temperature Compensation.



Note : Q₂ is connected as a diode in order to compensate the variation of the Q₁ V_{BE} with the temperature. C allows a slow rise-time of the V_O

Figure 32 : Light Controllers ($V_o \min = V_{xx} + V_{BE}$).

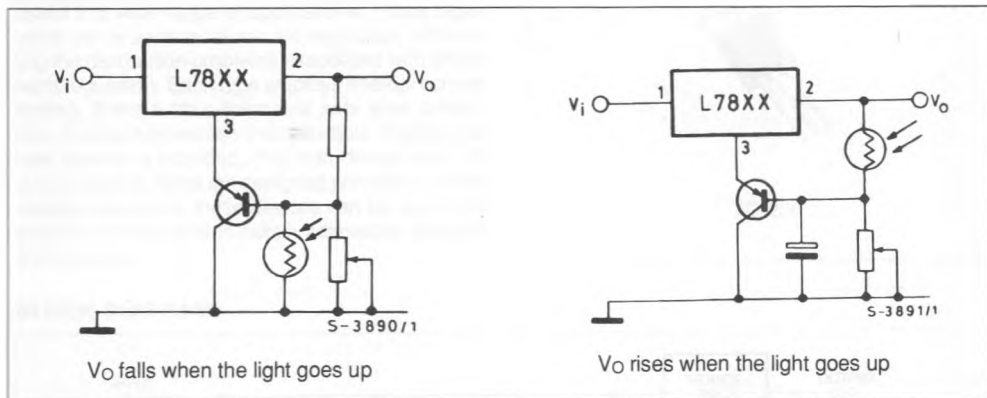
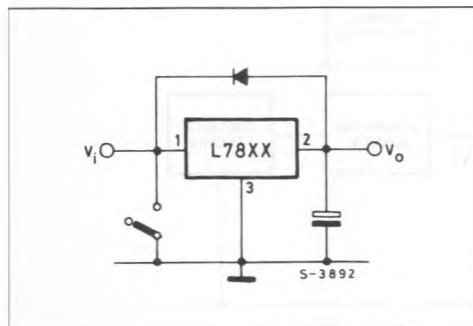

Figure 33 : Protection against Input Short-circuit with High Capacitance Loads.



Applications with high capacitance loads and an output voltage greater than 6 volts need an external diode (see fig 33) to protect the device against input short circuit. In this case the input voltage falls rapidly while the output voltage decreases slowly. The capacitance discharges by means of the Base-Emitter junction of the series pass transistor in the regulator. If the energy is sufficiently high, the transistor may be destroyed. The external diode by-passes the current from the IC to ground.