

## 2.5A POWER SWITCHING REGULATOR

PRELIMINARY DATA

- 2.5A OUTPUT CURRENT
- 5.1V TO 40V OUTPUT VOLTAGE RANGE
- PRECISE ( $\pm 2\%$ ) ON-CHIP REFERENCE
- HIGH SWITCHING FREQUENCY
- VERY HIGH EFFICIENCY (UP TO 90%)
- VERY FEW EXTERNAL COMPONENTS
- SOFT START
- INTERNAL LIMITING CURRENT
- THERMAL SHUTDOWN

The L4960 is a monolithic power switching regulator delivering 2.5A at a voltage variable from 5V to 40V in step down configuration. Features of the device include current limiting,

soft start, thermal protection and 0 to 100% duty cycle for continuous operation mode.

The L4960 is mounted in a Heptawatt plastic package and requires very few external components.

Efficient operation at switching frequencies up to 150KHz allows a reduction in the size and cost of external filter components.

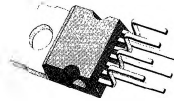

Heptawatt

**ORDERING NUMBER:** L4960 (Vertical)  
L4960H (Horizontal)

### ABSOLUTE MAXIMUM RATINGS

$V_1$	Input voltage	50	V
$V_1 - V_7$	Input to output voltage difference	50	V
$V_7$	Negative output DC voltage	-1	V
	Negative output peak voltage at $t = 0.1\mu s$ ; $f = 100\text{KHz}$	-5	V
$V_3, V_6$	Voltage at pin 3 and 6	5.5	V
$V_2$	Voltage at pin 2	7	V
$I_3$	Pin 3 sink current	1	mA
$I_5$	Pin 5 source current	20	mA
$P_{tot}$	Power dissipation at $T_{case} \leq 90^\circ\text{C}$	15	W
$T_j, T_{stg}$	Junction and storage temperature	-40 to 150	$^\circ\text{C}$

### BLOCK DIAGRAM

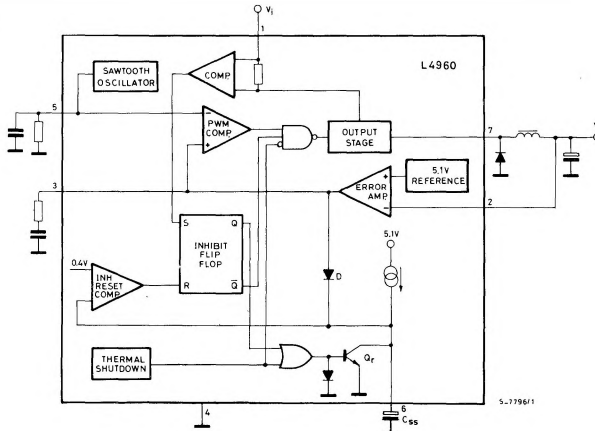

## CONNECTION DIAGRAM

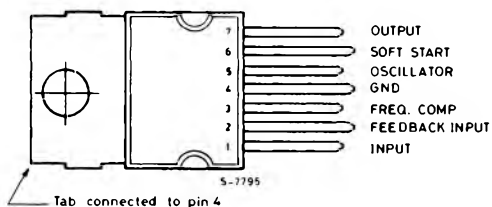

## THERMAL DATA

$R_{th\ j-case}$	Thermal resistance junction-case	max	4	$^{\circ}C/W$
$R_{th\ j-amb}$	Thermal resistance junction-ambient	max	50	$^{\circ}C/W$

## PIN FUNCTIONS

N <sup>o</sup>	NAME	FUNCTION
1	SUPPLY VOLTAGE	Unregulated voltage input. An internal regulator powers the internal logic.
2	FEEDBACK INPUT	The feedback terminal of the regulation loop. The output is connected directly to this terminal for 5.1V operation; it is connected via a divider for higher voltages.
3	FREQUENCY COMPENSATION	A series RC network connected between this terminal and ground determines the regulation loop gain characteristics.
4	GROUND	Common ground terminal.
5	OSCILLATOR	A parallel RC network connected to this terminal determines the switching frequency.
6	SOFT START	Soft start time constant. A capacitor is connected between this terminal and ground to define the soft start time constant. This capacitor also determines the average short circuit output current.
7	OUTPUT	Regulator output.

**ELECTRICAL CHARACTERISTICS** (Refer to the test circuit,  $T_j = 25^\circ\text{C}$ ,  $V_i = 35\text{V}$ , unless otherwise specified)

Parameter	Test Conditions	Min.	Typ.	Max.	Unit
-----------	-----------------	------	------	------	------

### DYNAMIC CHARACTERISTICS

$V_o$	Output voltage range	$V_i = 46\text{V}$	$I_o = 1\text{A}$	$V_{ref}$	40	V	
$V_i$	Input voltage range	$V_o = V_{ref}$ to 36V	$I_o = 2.5\text{A}$	9	46	V	
$\Delta V_o$	Line regulation	$V_i = 10\text{V}$ to 40V	$V_o = V_{ref}$ $I_o = 1\text{A}$		15	50	mV
$\Delta V_o$	Load regulation	$V_o = V_{ref}$	$I_o = 0.5\text{A}$ to 2A		10	30	mV
$V_{ref}$	Internal reference voltage (pin 2)	$V_i = 9\text{V}$ to 46V	$I_o = 1\text{A}$	5	5.1	5.2	V
$\frac{\Delta V_{ref}}{\Delta T}$	Average temperature coefficient of refer. voltage	$T_j = 0^\circ\text{C}$ to $125^\circ\text{C}$	$I_o = 1\text{A}$		0.4		mV/ $^\circ\text{C}$
$V_d$	Dropout voltage	$I_o = 2\text{A}$			1.4	3	V
$I_{om}$	Maximum operating load current	$V_i = 9\text{V}$ to 46V	$V_o = V_{ref}$ to 36V	2.5			A
$I_{7L}$	Current limiting threshold (pin 7)	$V_i = 9\text{V}$ to 46V	$V_o = V_{ref}$ to 36V	3		4.5	A
$I_{5H}$	Input average current	$V_i = 46\text{V}$ ; output short-circuit			30	60	mA
$\eta$	Efficiency	$f = 100\text{KHz}$ $I_o = 2\text{A}$	$V_o = V_{ref}$		75		%
			$V_o = 12\text{V}$		85		%
SVR	Supply voltage ripple rejection	$\Delta V_i = 2V_{rms}$ $f_{ripple} = 100\text{Hz}$ $V_o = V_{ref}$	$I_o = 1\text{A}$	50	56		dB
f	Switching frequency			85	100	115	KHz
$\frac{\Delta f}{\Delta V_i}$	Voltage stability of switching frequency	$V_i = 9\text{V}$ to 46V			0.5		%
$\frac{\Delta f}{\Delta T_j}$	Temperature stability of switching frequency	$T_j = 0^\circ\text{C}$ to $125^\circ\text{C}$			1		%
$f_{max}$	Maximum operating switching frequency	$V_o = V_{ref}$	$I_o = 2\text{A}$	120	150		KHz
$T_{sd}$	Thermal shutdown junction temperature				150		$^\circ\text{C}$

## ELECTRICAL CHARACTERISTICS (continued)

Parameter	Test Conditions	Min.	Typ.	Max.	Unit
-----------	-----------------	------	------	------	------

## DC CHARACTERISTICS

$I_{1Q}$	Quiescent drain current	100% duty cycle pins 5 and 7 open	$V_1 = 46V$		30	40	mA
		0% duty cycle			15	20	mA
$-I_{7L}$	Output leakage current	0% duty cycle					1

## SOFT START

$I_{6SO}$	Source current		100	130	150	$\mu A$
$I_{6SI}$	Sink current		50	70	120	$\mu A$

## ERROR AMPLIFIER

$V_{3H}$	High level output voltage	$V_2 = 4.7V$	$I_3 = 100\mu A$	3.5			V
$V_{3L}$	Low level output voltage	$V_2 = 5.3V$	$I_3 = 100\mu A$			0.5	V
$I_{3SI}$	Sink output current	$V_2 = 5.3V$		100	150		$\mu A$
$-I_{3SO}$	Source output current	$V_2 = 4.7V$		100	150		$\mu A$
$I_2$	Input bias current	$V_2 = 5.2V$			2	10	$\mu A$
$G_V$	DC open loop gain	$V_3 = 1V$ to $3V$		46	55		dB

## OSCILLATOR

$-I_5$	Oscillator source current		5				mA
--------	---------------------------	--	---	--	--	--	----

## CIRCUIT OPERATION (refer to the block diagram)

The L4960 is a monolithic stepdown switching regulator providing output voltages from 5.1V to 40V and delivering 2.5A.

The regulation loop consists of a sawtooth oscillator, error amplifier, comparator and the output stage. An error signal is produced by comparing the output voltage with a precise 5.1V on-chip reference (zener zap trimmed to  $\pm 2\%$ ).

This error signal is then compared with the sawtooth signal to generate the fixed frequency pulse width modulated pulses which drive the output stage.

The gain and frequency stability of the loop can be adjusted by an external RC network connected to pin 3. Closing the loop directly gives an output voltage of 5.1V. Higher voltages are obtained by inserting a voltage divider.

Output overcurrents at switch on are prevented by the soft start function. The error amplifier output is initially clamped by the external capacitor  $C_{SS}$  and allowed to rise, linearly, as this capacitor is charged by a constant current source. Output overload protection is provided in the form of a current limiter. The load current is sensed by an internal metal resistor connected to a comparator. When the load current exceeds a preset threshold this comparator sets a flip flop which disables the output stage and discharges the soft start capacitor. A second comparator resets the flip flop when the voltage across the soft start capacitor has fallen to 0.4V.

The output stage is thus re-enabled and the output voltage rises under control of the soft start network. If the overload condition is still present the limiter will trigger again when the threshold current is reached. The average short circuit current is limited to a safe value by the dead time introduced by the soft start network. The thermal overload circuit disables circuit operation when the junction temperature reaches about  $150^{\circ}\text{C}$  and has hysteresis to prevent unstable conditions.

The output stage is thus re-enabled and the output voltage rises under control of the soft start network. If the overload condition is still present the limiter will trigger again when the threshold current is reached. The average short circuit current is limited to a safe value by the dead time introduced by the soft start network. The thermal overload circuit disables circuit operation when the junction temperature reaches about  $150^{\circ}\text{C}$  and has hysteresis to prevent unstable conditions.

Fig. 1 - Soft start waveforms

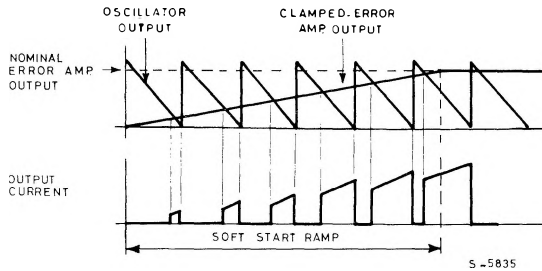

Fig. 2 - Current limiter waveforms

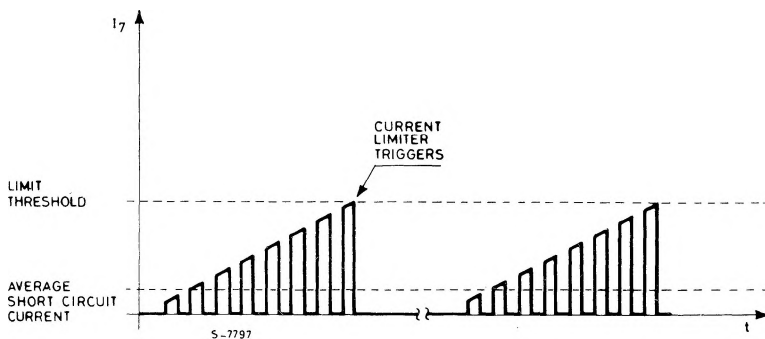
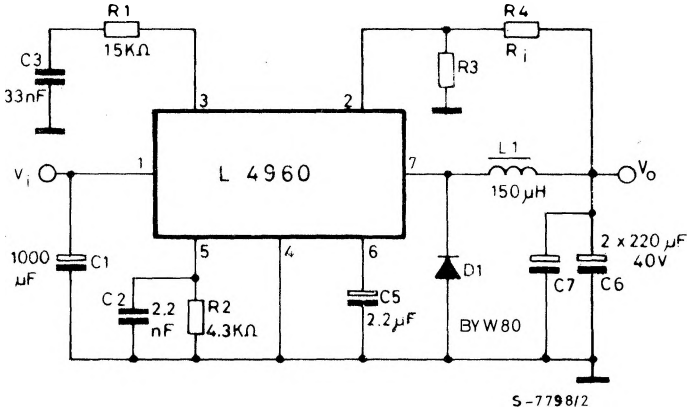

Fig. 3 - Test and application circuit



C6, C7: EKR (ROE)  
 L1 = 150μH at 5A (COGEMA 946042)  
 CORE TYPE: MAGNETICS 58206-A2 MPP  
 N° TURNS 45, WIRE GAUGE: 0.8mm (20 AWG)

S-7798/2

Fig. 4 - Quiescent drain current vs. supply voltage (0% duty cycle)

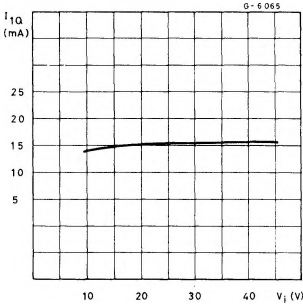

Fig. 5 - Quiescent drain current vs. supply voltage (100% duty cycle)

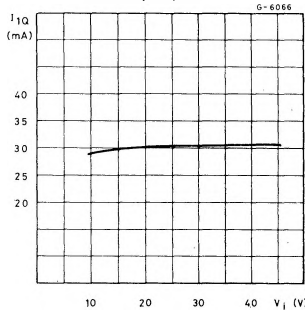

Fig. 6 - Quiescent drain current vs. junction temperature (0% duty cycle)

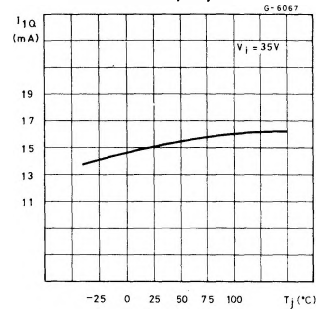

Fig. 7 - Quiescent drain current vs. junction temperature (100% duty cycle)

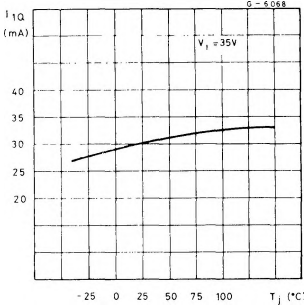

Fig. 8 - Reference voltage (pin 2) vs.  $V_i$

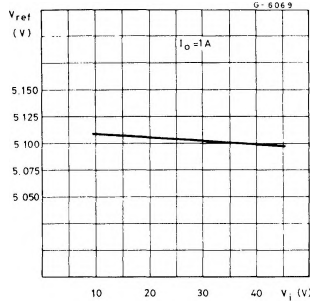

Fig. 9 - Reference voltage vs. junction temperature (pin 2)

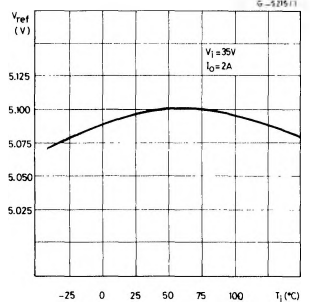

Fig. 10 - Open loop frequency and phase response of error amplifier

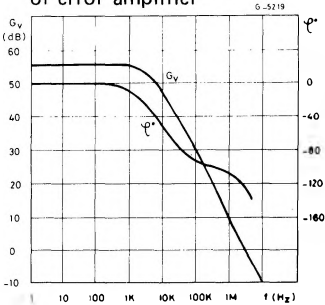

Fig. 11 - Switching frequency vs. input voltage

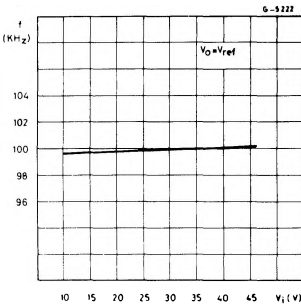

Fig. 12 - Switching frequency vs. junction temperature

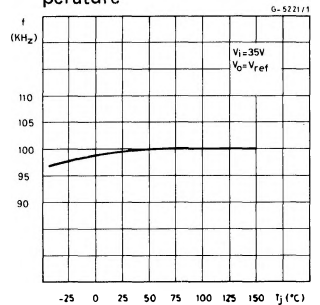

Fig. 13 - Switching frequency vs. R2 (see test circuit)

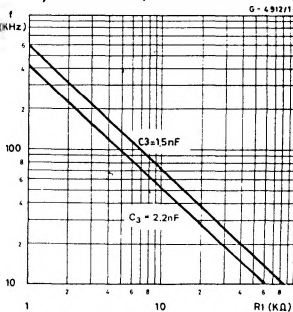

Fig. 14 - Line transient response

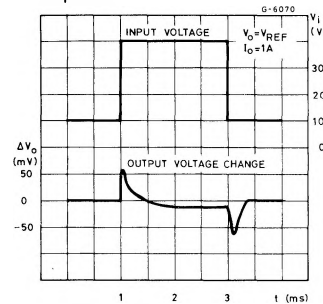

Fig. 15 - Load transient response

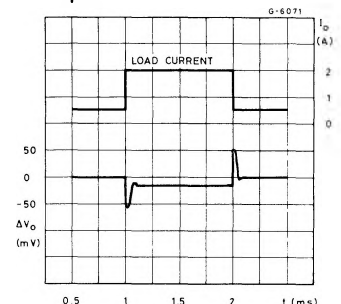

Fig. 16 - Supply voltage ripple rejection vs. frequency

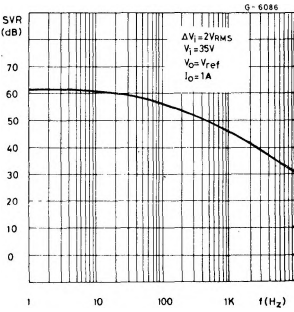

Fig. 17 - Dropout voltage between pin 1 and pin 7 vs. current at pin 7

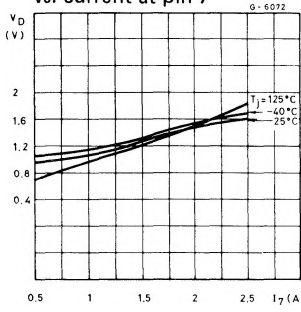

Fig. 18 - Dropout voltage between pin 1 and 7 vs. junction temperature

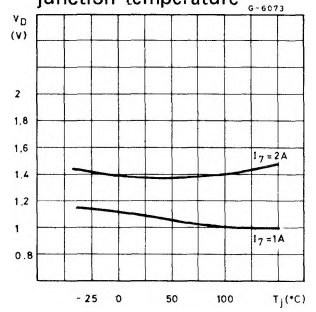

Fig. 19 - Power dissipation derating curve

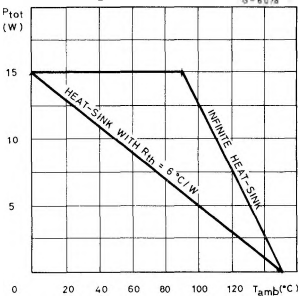

Fig. 20 - Efficiency vs. output current

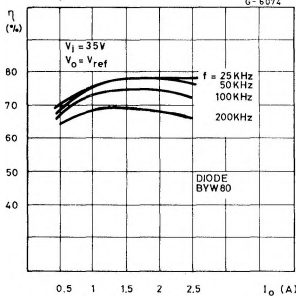

Fig. 21 - Efficiency vs. output current

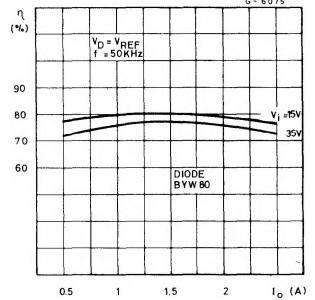

Fig. 22 - Efficiency vs. output current

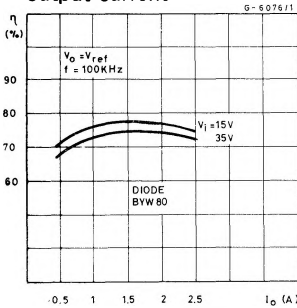
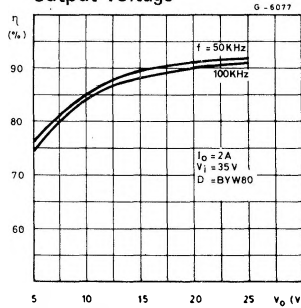
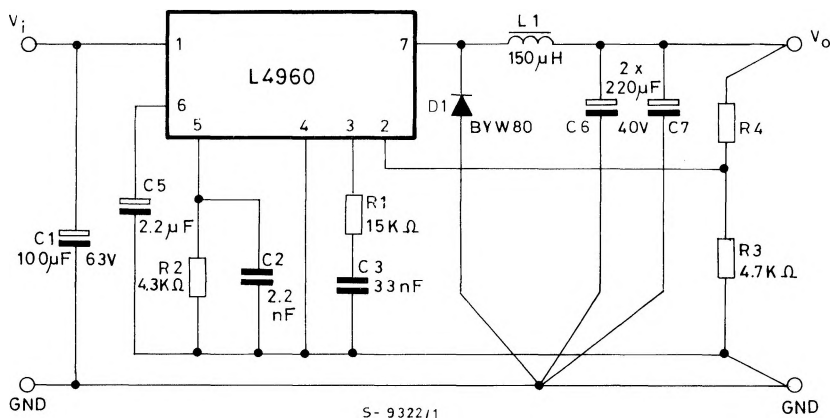

Fig. 23 - Efficiency vs. output voltage



## APPLICATION INFORMATION

Fig. 24 - Typical application circuit



C<sub>1</sub>, C<sub>6</sub>, C<sub>7</sub>: EKR (ROE)

D<sub>1</sub>: BYW80 OR 5A SCHOTTKY DIODE

SUGGESTED INDUCTOR: L<sub>1</sub> = 150µH at 5A

CORE TYPE: MAGNETICS 58206 - A2 - MPP

N<sup>o</sup> TURNS: 45, WIRE GAUGE: 0.8mm (20 AWG), COGEMA 946042

U15/GUP15: N<sup>o</sup> TURNS: 60, WIRE GAUGE: 0.8mm (20 AWG), AIR GAP: 1mm, COGEMA 969051.

Fig. 25 - P.C. board and component layout of the Fig. 24 (1 : 1 scale)

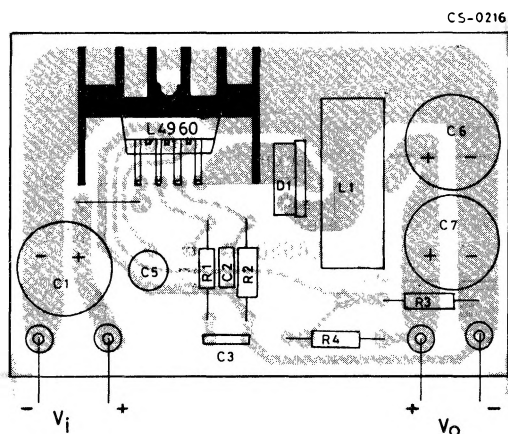

Resistor values for standard output voltages

V <sub>o</sub>	R3	R4
12V	4.7KΩ	6.2KΩ
15V	4.7KΩ	9.1KΩ
18V	4.7KΩ	12KΩ
24V	4.7KΩ	18KΩ

APPLICATION INFORMATION (continued)

Fig. 26 - A minimal 5.1V fixed regulator; Very few component are required

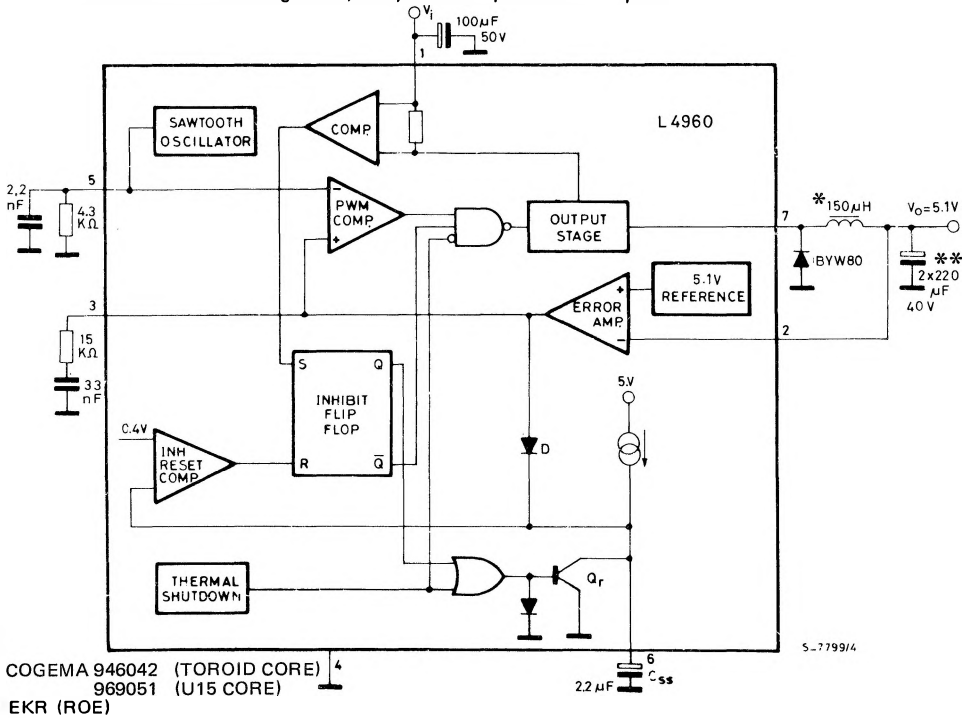
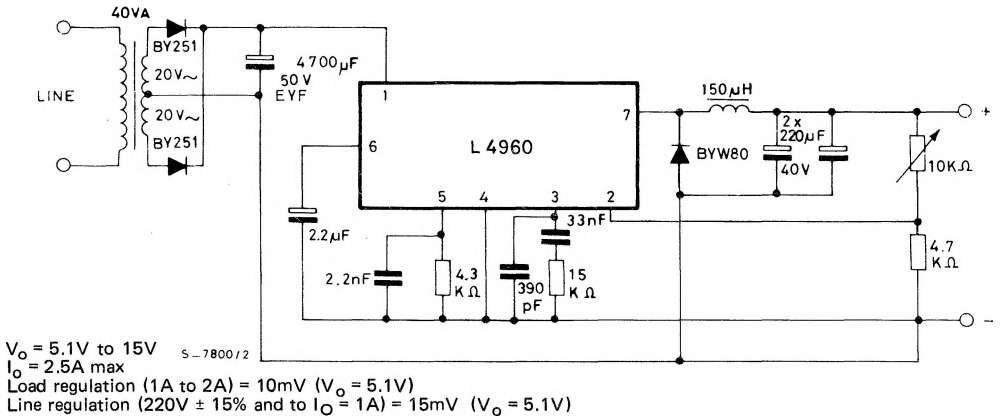
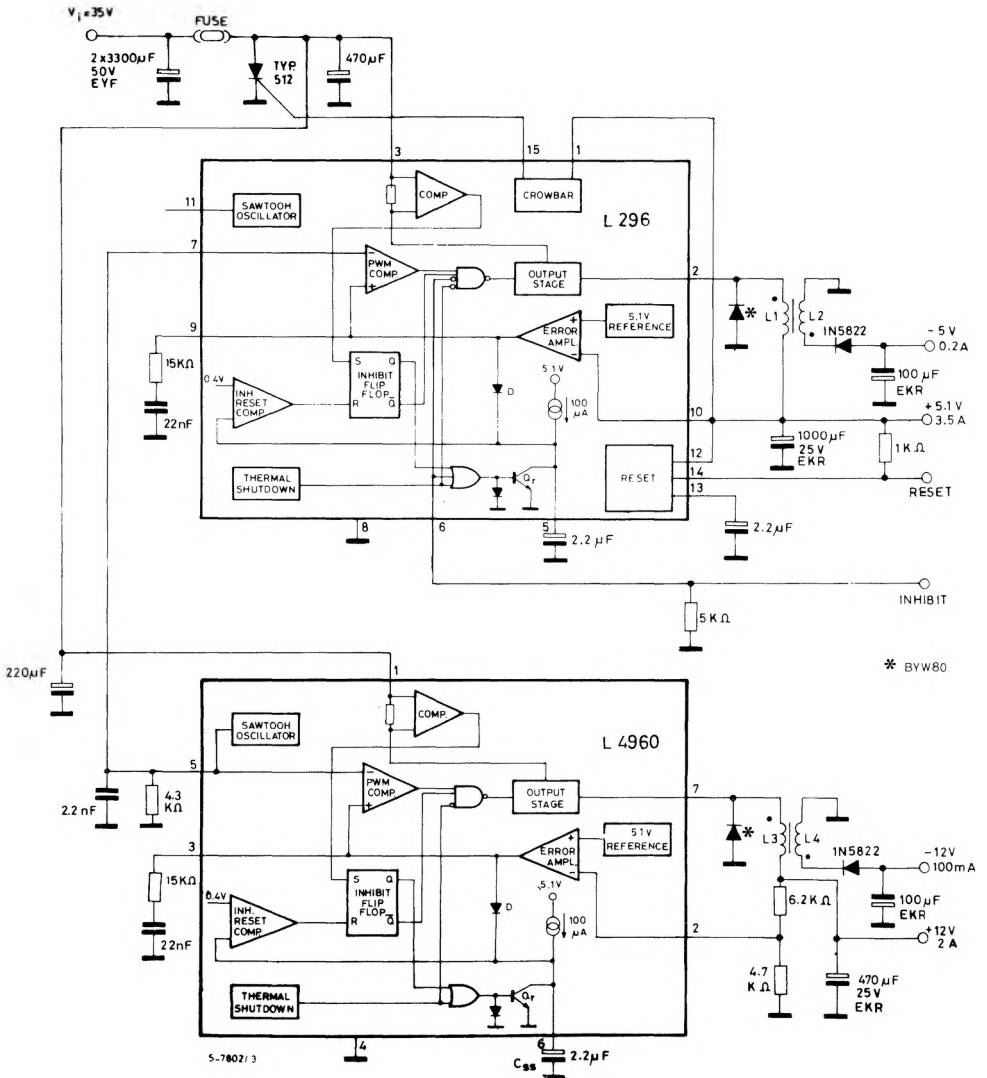

Fig. 27 - Programmable power supply



APPLICATION INFORMATION (continued)

Fig. 28 - Microcomputer supply with + 5.1V, -5V, +12V and -12V outputs



APPLICATION INFORMATION (continued)

Fig. 29 - DC-DC converter 5.1V/4A,  $\pm 12V/2.5A$ ; a suggestion how to synchronize a negative output

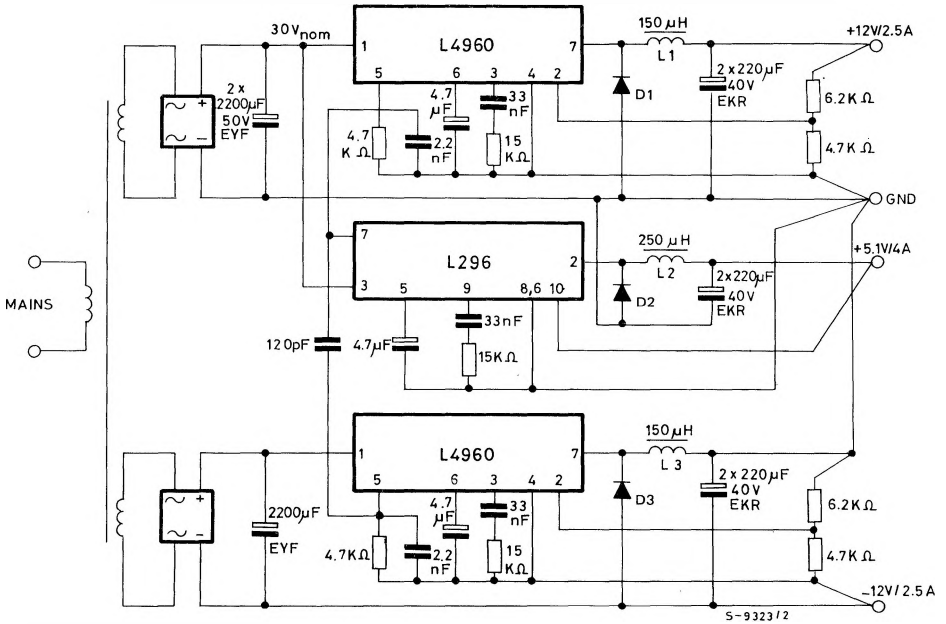

- L1, L3 = COGEMA 946042 (969051)
- L2 = COGEMA 946044 (946045)
- D1, D2, D3 = 8YW80

Fig. 30 - In multiple supplies several L4960s can be synchronized as shown

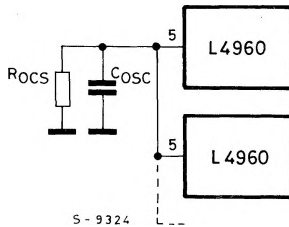

## APPLICATION INFORMATION (continued)

Fig. 31 - Regulator for distributed supplies

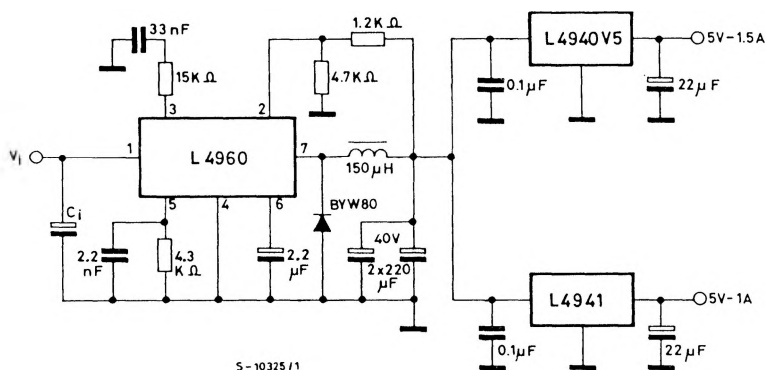

## MOUNTING INSTRUCTION

The power dissipated in the circuit must be removed by adding an external heatsink.

Thanks to the Heptawatt package attaching the heatsink is very simple, a screw or a compression spring (clip) being sufficient. Between the heatsink

and the package it is better to insert a layer of silicon grease, to optimize the thermal contact, no electrical isolation is needed between the two surfaces.

Fig. 32 - Mounting example

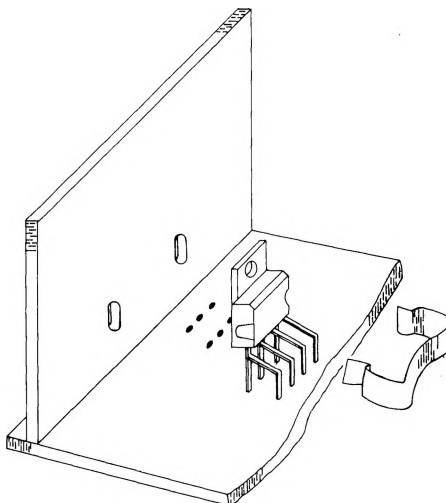

S - 6392