



LINEAR INTEGRATED CIRCUIT

TELEPHONE SPEECH CIRCUIT WITH MULTIFREQUENCY TONE GENERATOR INTERFACE

The LS356 is a monolithic integrated circuit in 16-lead dual in-line plastic package to replace the hybrid circuit in telephone set. It works with the same type of transducers for both transmitter and receiver (typically dynamic capsules, but the device can also work with piezoceramic ones). Many of its electrical characteristics can be controlled by means of external components to meet different specifications.

In addition to the speech operation, the LS356 acts as an interface for the MF tone signal (particularly for M761 C/MOS frequency synthesizer).

The LS356 basic functions are the following:

- It presents the proper DC path for the line current.
- It handles the voice signal, performing the 2/4 wires interface and changing the gain on both sending and receiving amplifiers to compensate for line attenuation by sensing either the line current or the line voltage. In addition, the LS356 can also work in fixed gain mode.
- It acts as linear interface for MF, supplying a stabilized voltage to the digital chip and delivering to the line the MF tones generated by the M761.

ABSOLUTE MAXIMUM RATINGS

V_L	Line voltage (3 ms pulse duration)	22	V
I_L	Forward line current	150	mA
I_{Lr}	Reverse line current	-150	mA
P_{tot}	Total power dissipation at $T_{amb} = 70^\circ\text{C}$	1	W
T_{op}	Operating temperature	-45 to 70	$^\circ\text{C}$
T_{stg}, T_J	Storage and junction temperature	-65 to 150	$^\circ\text{C}$

ORDERING NUMBER: LS356B

MECHANICAL DATA

Dimensions in mm

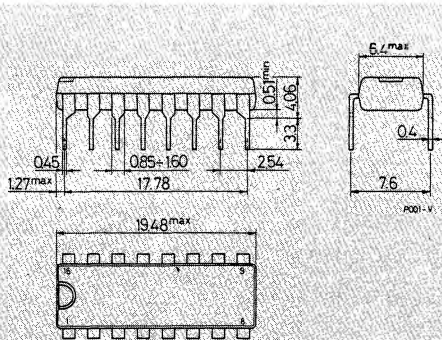



LS 956

CONNECTION DIAGRAM

(top view)

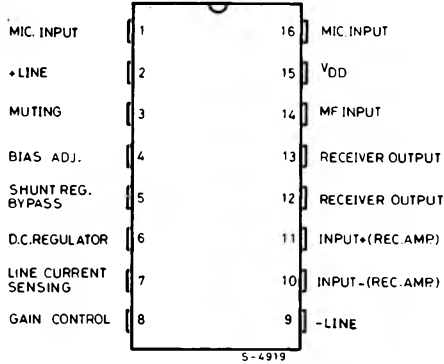

BLOCK DIAGRAM

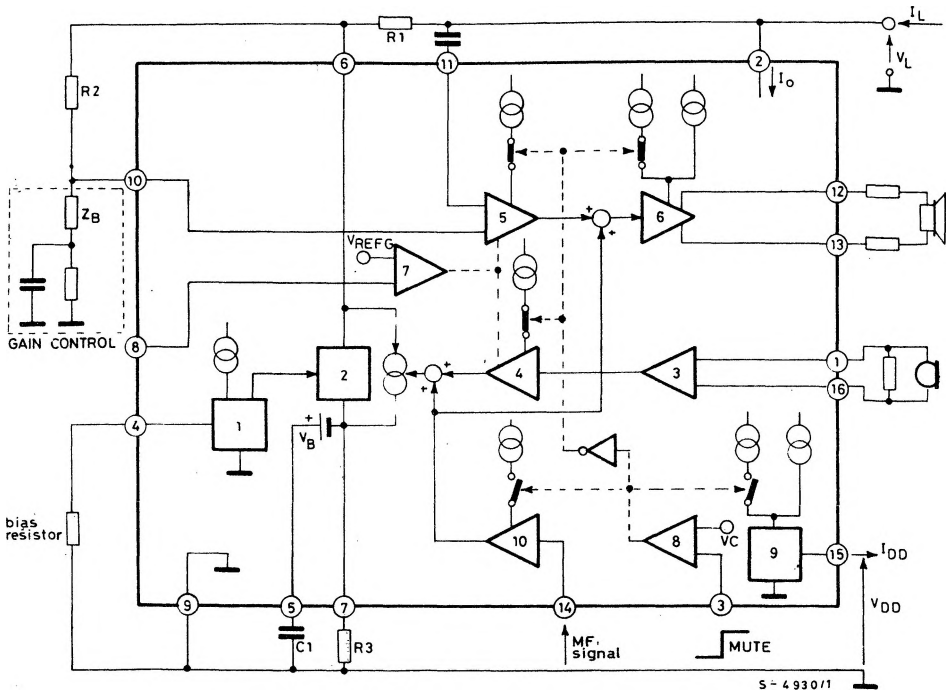

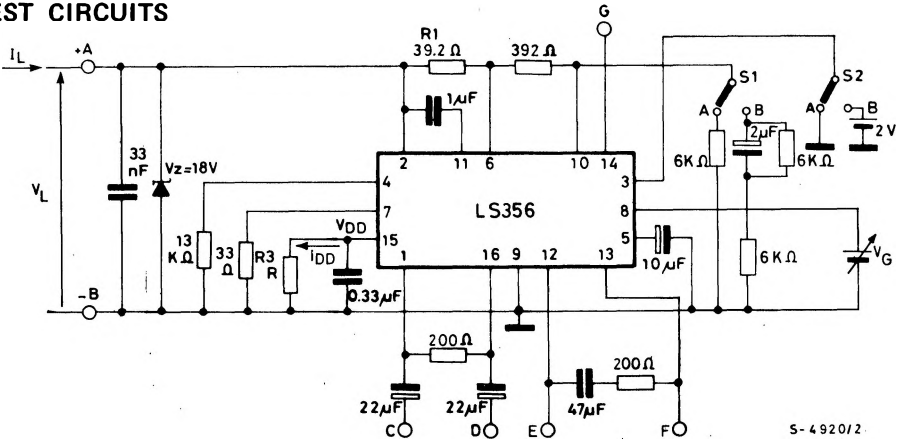
TEST CIRCUITS

S-4920/2

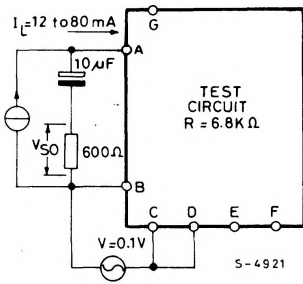
Fig. 1

CMRR

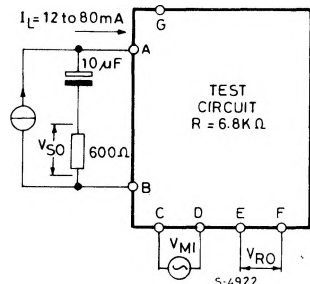
S-4921

Fig. 2

$$\text{Side tone} = \frac{V_{RO}}{V_{MI}}; G_s = \frac{V_{SO}}{V_{MI}}$$

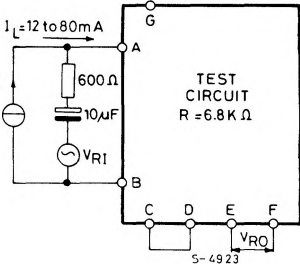
S-4922

Fig. 3

$$G_R = \frac{V_{RO}}{V_{RI}}$$

S-4923

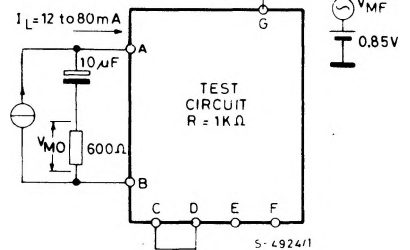
Fig. 4

$$G_{MF} = \frac{V_{MO}}{V_{MF}}$$

S-4924/1



LS 356

THERMAL DATA

$R_{th\ j-amb}$ Thermal resistance junction-ambient	max 80 °C/W
---	-------------

ELECTRICAL CHARACTERISTICS (Refer to the test circuits, $V_G = 1$ to 2V, $I_L = 12$ to 80 mA, S1 and S2 in (a), $T_{amb} = -25$ to $+50^\circ\text{C}$, $f = 200$ to 3400 Hz, unless otherwise specified)

Parameter	Test conditions	Min.	Typ.	Max.	Unit	Fig.
-----------	-----------------	------	------	------	------	------

SPEECH OPERATION

V_L Line voltage	$T_{amb} = 25^\circ\text{C}$ $I_L = 12\text{ mA}$ $I_L = 20\text{ mA}$ $I_L = 80\text{ mA}$	3.9		4.7 5.5 12.2	V	-
CMRR Common mode rejection	$f = 1\text{ KHz}$	50			dB	1
G_S Sending gain	$T_{amb} = 25^\circ\text{C}$ $f = 1\text{ KHz}$ $V_G = 2\text{ V}$ $V_{MI} = 3\text{ mV}$ $V_G = 1\text{ V}$	44 48		46 50	dB	2
Sending gain flatness (vs. frequency)	$V_{MI} = 3\text{ mV}$ $f_{ref} = 1\text{ KHz}$			± 1	dB	2
* Sending gain flatness (vs. current)				± 0.5	dB	2
Sending distortion	$f = 1\text{ KHz}$ $V_{so} = 1\text{ V}$ $V_{so} = 1.3\text{ V}$			2 10	%	2
Sending noise	$V_{MI} = 0\text{ V}$ $V_G = 1\text{ V}$			-70	dBmp	2
Microphone input impedance (pin 1-16)	$V_{MI} = 3\text{ mV}$	40			$K\Omega$	-
Sending gain in MF operation	$V_{MI} = 3\text{ mV}$ S2 in (b)	-30			dB	2
G_R Receiving gain	$V_{RI} = 0.3\text{ V}$ $V_G = 2\text{ V}$ $f = 1\text{ KHz}$ $V_G = 1\text{ V}$ $T_{amb} = 25^\circ\text{C}$	-3 -1	-4 0	-5 1	dB	3
Receiving gain flatness (vs. frequency)	$V_{RI} = 0.3\text{ V}$ $f_{ref} = 1\text{ KHz}$			± 1	dB	3
* Receiving gain flatness (vs. current)				± 0.5	dB	3
Receiving distortion	$f = 1\text{ KHz}$ $V_{RO} = 400\text{ mV}$ $V_{RO} = 480\text{ mV}$		10	2	%	3
Receiving noise	$V_{RI} = 0\text{ V}$		100		μV	3
Receiver output impedance (pin 12-13)	$V_{RO} = 50\text{ mV}$			100	Ω	-
Sidetone	$f = 1\text{ KHz}$ $T_{amb} = 25^\circ\text{C}$ S1 in (b)			36	dB	2
Z_{ML} Line matching impedance	$V_{RI} = 0.3\text{ V}$ $f = 1\text{ KHz}$	500	600	700	Ω	3
I_B Input current for gain control (pin 8)				-10	μA	-

* Fixed gain mode.

ELECTRICAL CHARACTERISTICS (continued)

Parameter	Test conditions	Min.	Typ.	Max.	Unit	Fig.
-----------	-----------------	------	------	------	------	------

MULTIFREQUENCY SYNTHESIZER INTERFACE

V_{DD}	MF supply voltage (Standby and operation)	S2 in (b)	2.4	2.5		V	—
I_{DD}	MF supply current	Standby Operation	0.5 2			mA	—
	MF amplifier gain	$f_{MF\ in} = 1\ KHz$ $V_{MF\ in} = 80\ mV$	15		17	dB	4
V_I	DC input voltage level (pin 14)	$V_{MF\ in} = 80\ mV$		0.3 V_{DD}		V	—
R_I	Input impedance (pin 14)	$V_{MF\ in} = 80\ mV$	60			$K\Omega$	—
d	Distortion	$V_{MF\ in} = 110\ mV$			2	%	4
	Starting delay time				5	ms	—
	Muting threshold voltage (pin 3)	Speech operation			1	V	—
		MF operation	1.6			V	—
	Muting standby current (pin 3)				-10	μA	—
	Muting operating current (pin 3)	S2 in (b)			+10	μA	—

CIRCUIT DESCRIPTION

1. DC characteristic

The fig. 5 shows the DC equivalent circuit of the LS356.

Fig. 5 - Equivalent DC load to the line

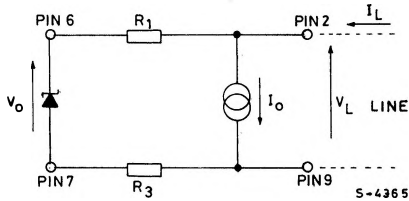

A fixed amount I_o of the total available current I_L is drained for the proper operation of the circuit. The value of I_o can be programmed externally by changing the value of the bias resistor connected to pin 4 (see block diagram).

The minimum value of I_o is 7.5 mA.

The voltage $V_o = 3.8V$ of the shunt regulator is independent of the line current.

The shunt regulator (2) is controlled by a temperature compensated voltage reference (1) (see the block diagram).

Fig. 6 shows a more detailed circuit configuration of the shunt regulator.

Fig. 6 - Circuit configuration of the shunt regulator

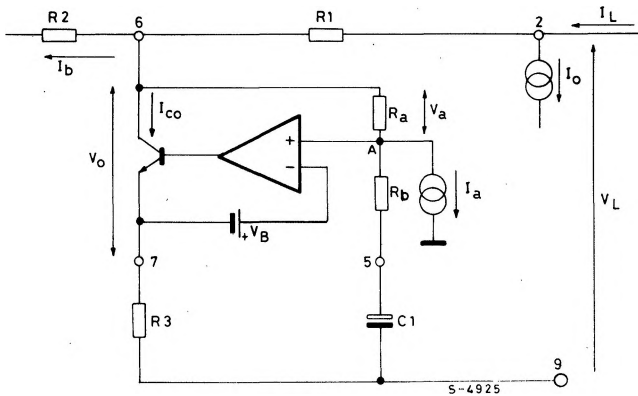

The difference $I_L - I_o$ flows through the shunt regulator being I_b negligible.

I_a is an internal constant current generator; hence $V_o = V_B + I_a \cdot R_a = 3.8V$.

The V_L , I_L characteristic of the device is therefore similar to a pure resistance in series to a battery. It is important to note that the DC voltage at pin 5 is proportional to the line current ($V_5 = V_7 + V_B = (I_L - I_o) R_3 + V_B$).

CIRCUIT DESCRIPTION (continued)

2. Two to four wires conversion

The LS356 performs the two wires (line) to four wires (microphone, earphone) conversion by means of a Wheatstone bridge configuration so obtaining the proper decoupling between sending and receiving signals (see fig. 7).

Fig. 7 - Two to four wires conversion

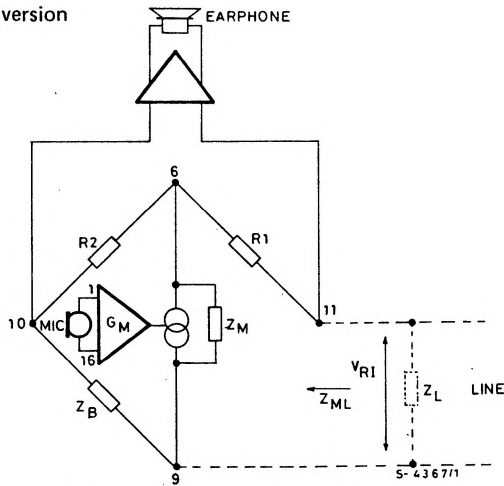

For a perfect balancing of the bridge $\frac{Z_L}{Z_B} = \frac{R_1}{R_2}$.

The AC signal from the microphone is sent to one diagonal of the bridge (pin 6 and 9). A small percentage of the signal power is lost on Z_B (being $Z_B \gg Z_L$); the main part is sent to the line via R_1 .

In receiving mode, the AC signal coming from the line is sensed across the second diagonal of the bridge (pin 11 and 10). After amplification it is applied to the receiving capsule.

The impedance Z_M is simulated by the shunt regulator that is also intended to work as a transconductance amplifier for the transmission signal.

The impedance Z_M is defined as $\frac{\Delta V_{6-9}}{\Delta I_{6-9}}$.

From fig. 6 considering C_1 as a short circuit for AC signal, any variation ΔV_6 generates a variation:

$$\Delta V_7 = \Delta V_A = \Delta V_6 \cdot \frac{R_b}{R_a + R_b}$$

The corresponding current change is

$$\Delta I = \frac{\Delta V_7}{R_3}$$

Therefore

$$Z_M = \frac{\Delta V_6}{\Delta I} = R_3 \left(1 + \frac{R_a}{R_b} \right)$$

CIRCUIT DESCRIPTION (continued)

The total impedance across the line connections (pin 11 and 9) is given by

$$Z_{ML} = R1 + Z_M // (R2 + Z_B)$$

By choosing $Z_M \gg R1$ and $Z_B \gg Z_M$

$$Z_{ML} \cong Z_M = R3 \left(1 + \frac{R_a}{R_b}\right)$$

The received signal amplitude across pin 11 and 10 can be changed using different values of $R1$ (of course the relationship $Z_L/Z_B = R1/R2$ must be always valid).

The received signal is related to $R1$ value according to the approximated relationship:

$$V_R = 2 V_{R1} \frac{R1}{R1 + Z_M}$$

Note that by changing the value of $R1$, the transmission signal current is not changed, being the microphone amplifier a transconductance amplifier.

3. Automatic gain control

The LS356 automatically adjusts the gain of the sending and receiving amplifiers to compensate for line attenuation.

This function is performed by the circuit of fig. 8.

Fig. 8

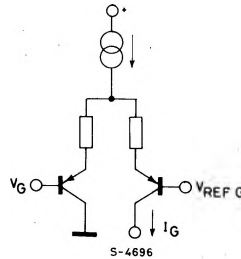

The differential stage is progressively unbalanced by changing V_G in the range 1 to 2V (V_{REFG} is an internal reference voltage, temperature compensated).

It changes the current I_G , and this current is used as a control quantity for the variable gain stages (amplifier (4) and (5) in the block diagram). The voltage V_G can be taken:

- from the LS356 itself (both in variable and in fixed mode) and
- from a resistive divider, directly at the end of the line.

- In the first case, connecting V_G (pin 8) to the regulator bypass (pin 5) it is possible to obtain a gain characteristic depending on the current.

In fact (see fig. 6):

$$V_5 = V_B + V_7 \cong V_B + (I_L - I_o) R3$$

The starting point of the automatic level control is obtained at $I_L = 25$ mA when the drain current $I_o = 7.5$ mA.

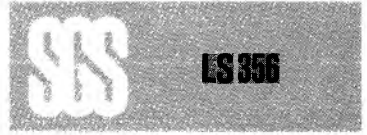

CIRCUIT DESCRIPTION (continued)

Minimum gain is reached for a line current of about 52 mA for the same drain current $I_o = 7.5$ mA. When I_o is increased by means of the external resistor connected to pin 4, the two above mentioned values of the line current for the starting point and for the minimum gain increase accordingly.

It is also possible to change the starting point without changing I_o by connecting pin 8 to the centre of a resistive divider placed between pin 5 and ground (the total resistance seen by pin 5 must be at least 100 K Ω). In this case, the AGC range increases too; for example using a division 1:1 (50K/50K) the AGC starting point shifts to about $I_L = 40$ mA, and the minimum gain is obtained at $I_L = 95$ mA. In addition to this operation mode, the V_G voltage can be maintained constant thus fixing the gain values (Rx, Tx) independently of the line conditions.

For this purpose the V_{DD} voltage, available for supplying the MF generator, can be used.

- b) When gains have to be related to the voltage at the line terminals of the telephone set, it is necessary to obtain V_G from a resistive divider directly connected to the end of the line.

This type of operation meets for instance the requirements of the French standard. (See the application circuit of fig. 12).

4. Transducers interfacing

The microphone amplifier (3) has a differential input stage with high impedance ($\cong 40$ K Ω) so allowing a good matching to the microphone by means of external resistor without affecting the sending gain. The receiving output stage (6) is particularly intended to drive dynamic capsules. (Low output impedance, 100 Ω max; high current capability, 3 mA).

When a piezoceramic capsule is used, it is useful to increase the receiving gain by increasing R1 value (see the relationship for V_R).

With very low impedance transducer, DC decoupling by an external capacitor must be provided to prevent a large DC current flow across the transducer itself due to the receiving output stage offset.

5. Multifrequency interfacing

The LS356 acts as a linear interface for the Multifrequency synthesizer M761 according to a logical signal (mute function) present on pin 3.

When no key of the keyboard is pressed the mute state is low and the LS356 feeds the M761 through pin 15 with low voltage and low current (standby operation of the M761). The oscillator of the M761 is not operating.

When one key is pressed, the M761 sends a "high state" mute condition to the LS 356. A voltage comparator (8) of LS356 drives internal electronic switches: the voltage and the current delivered by the voltage supply (9) are increased to allow the operation of the oscillator.

This extra current is diverted by the receiving and sending section of the LS356 and during this operation the receiving output stage is partially inhibited and the input stages of sending and receiving amplifiers are switched OFF.

A controlled amount of the signalling is allowed to reach the earphone to give a feedback to the subscriber; the MF amplifier (10) delivers the dial tones to the sending paths.

The application circuit shown in fig. 9 fulfils the EUROPE II standard (-6, -8 dBm). If the EUROPE I levels are required (-9, -11 dBm) an external divider must be used (fig. 10).

The mute function can be used also when a temporary inhibition of the output signal is requested.



LS 356

APPLICATION INFORMATION

Fig. 9 - Application circuit with multifrequency (EUROPE II STD)

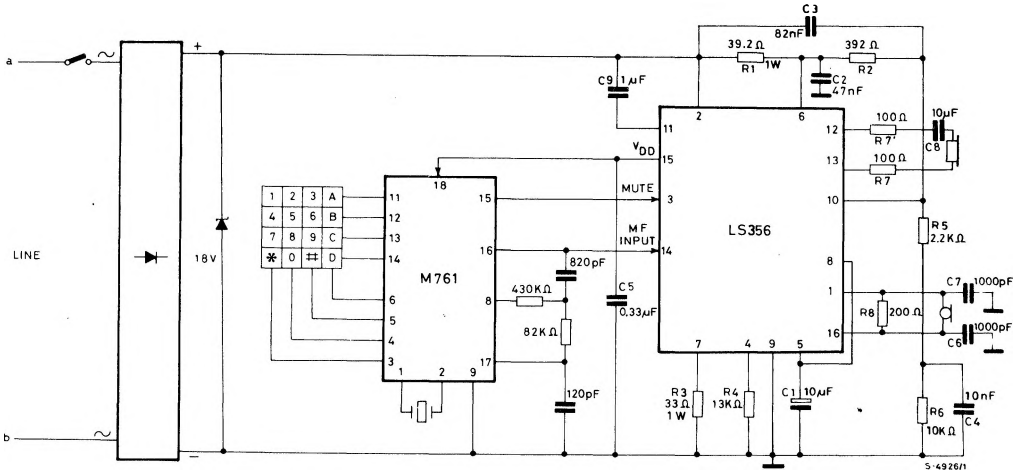
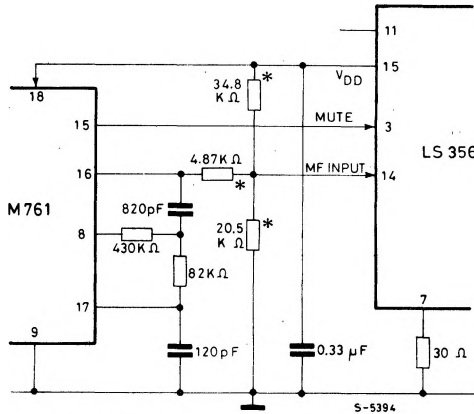
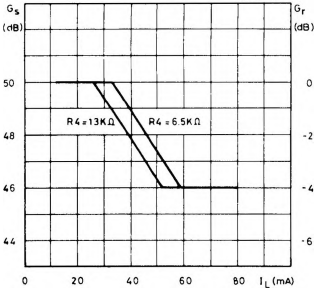
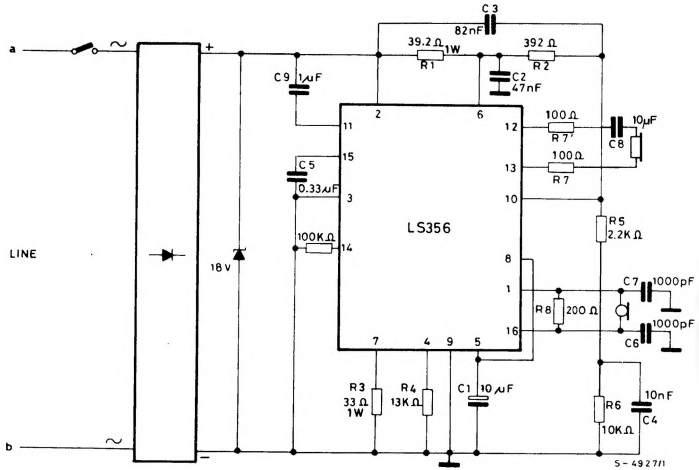
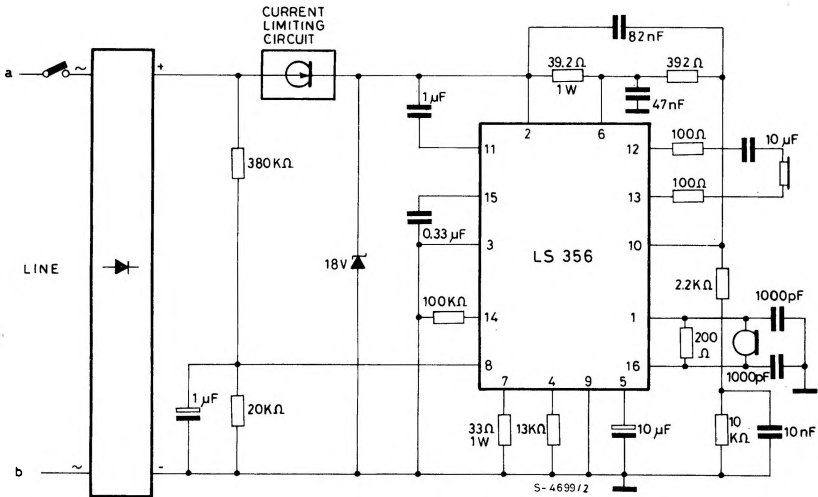
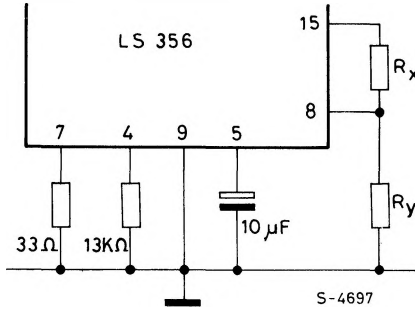

Fig. 10 - Application circuit with multifrequency (EUROPE I)



* TOLERANCE $\pm 2\%$

APPLICATION INFORMATION (continued)
Fig. 11 - Sending and receiving gain vs. line current (application circuit of fig. 13)

Fig. 12 - Application circuit without multifrequency

Fig. 13 - Application circuit with gain controlled by line voltage (French standard)

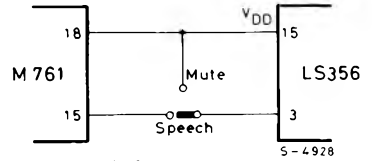
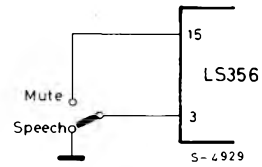
APPLICATION INFORMATION (continued)
Fig. 14 - Application circuit with fixed gain operation

$R_y = 0$ Max gain condition
 $R_x = 0$ Min gain condition

Fig. 15 - External mute function

a) with multifrequency

b) without multifrequency

In addition to the above mentioned applications, different values for the external components can be used in order to satisfy different requirements.

The following table (refer to the application circuit of fig. 9) can help the designers.

Component	Value	Purpose	Note
R1	39.2 Ω	Bridge Resistors	R1 controls the receiving gain. When high current values are allowed, R1 must be able to dissipate up to 1W. The ratio R2/R1 fixes the amount of signal delivered to the line. R1 helps in fixing the DC characteristic (see R3 note).
R2	392 Ω		
R3	33 Ω	Line current sensing. Fixing DC characteristic	The relationships involving R3 are: $- Z_{ML} = (20 R3 // Z_B) + R1$ $- G_s = K \cdot \frac{Z_L // Z_{ML}}{R3}$ $- V_L = (I_L - I_o) (R3 + R1) + V_o$ $V_o = 3.8V.$ Without any problem it is possible to have a Z_{ML} ranging from 600 up to 900 Ω. As far as the power dissipation is concerned, see R1 note.



APPLICATION INFORMATION (continued)

Component	Value	Purpose	Note
R4	13 K Ω	Bias Resistor	The suggested value assures the minimum operating current. It is possible to increase the supply current by decreasing R4 (they are inversely proportional), in order to achieve the shifting of the AGC starting point.
R5	2.2 K Ω	Balance Network	It is possible to change R5 and R6 values in order to improve the matching to different lines; in any case: $\frac{Z_B}{Z_L} = \frac{R2}{R1}$ $Z_B = R5 + R6 // X_{C4}$
R6	10 K Ω		
R7-R7'	100 Ω	Receiver impedance matching	R7 and R7' must be equal; the suggested value is good for matching to dynamic capsule; there is no problem in increasing and decreasing (down to 0 Ω) this value. A DC decoupling must be inserted when low resistance levels are used to stop the current due to the receiver output offset voltage (max 200 mV).
R8	200 Ω	Microphone impedance matching	The suggested value is typical for a dynamic microphone, but it is possible to choose R8 in a wide range.
C1	10 μ F	Regulator AC bypass	A value greater than 10 μ F gives a system start time too high for low current line during MF operation; a lower value gives an alteration of the AC line impedance at low frequency.
C2	47 nF	Matching to a capacitive line	C2 changes with the characteristics of the transmission line.
C3	82 nF	Receiving gain flatness	C3 depends on balancing and line impedance versus frequency
C4	10 nF	Balance, network	See note for R5, R6
C5	0.33 μ F	DC filtering	The C5 range is from 0.1 μ F to 0.47 μ F. The lowest value is ripple limited, the higher value is starting up time limited.
C6-C7	1000 pF	RF bypass	
C8	10 μ F	Receiving output DC decoupling	See note for R7, R7'.
C9	1 μ F	Receiving input DC decoupling	