

# AN8481SB

## Spindle motor driver IC for optical disk

### ■ Overview

The AN8481SB is a high performance IC suited for driving a spindle motor of an optical disk such as CD-ROM, PD, DVD, CD-R, CD-RW, etc.

### ■ Features

- Adopting the 3-phase full-wave soft switch system
- With switching regulator control function
- With start and stop pin
- Reverse breaking by EC/ECR voltage
- With Hall bias pin
- Surface-mount small package

### ■ Applications

- High speed CD-ROM drive
- PD, DVD, CD-R, CD-RW drives

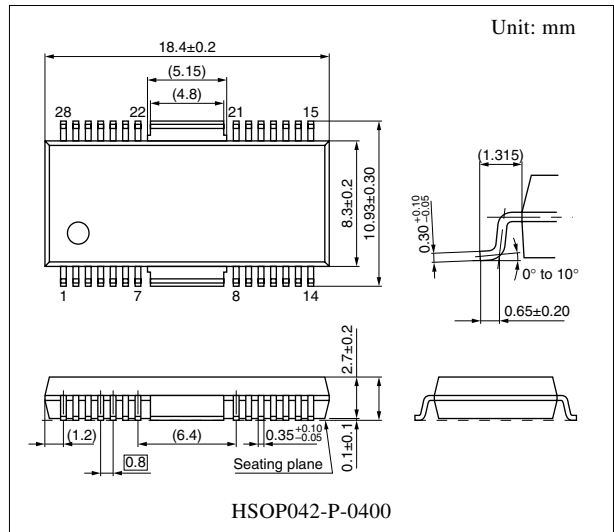

■ Block Diagram

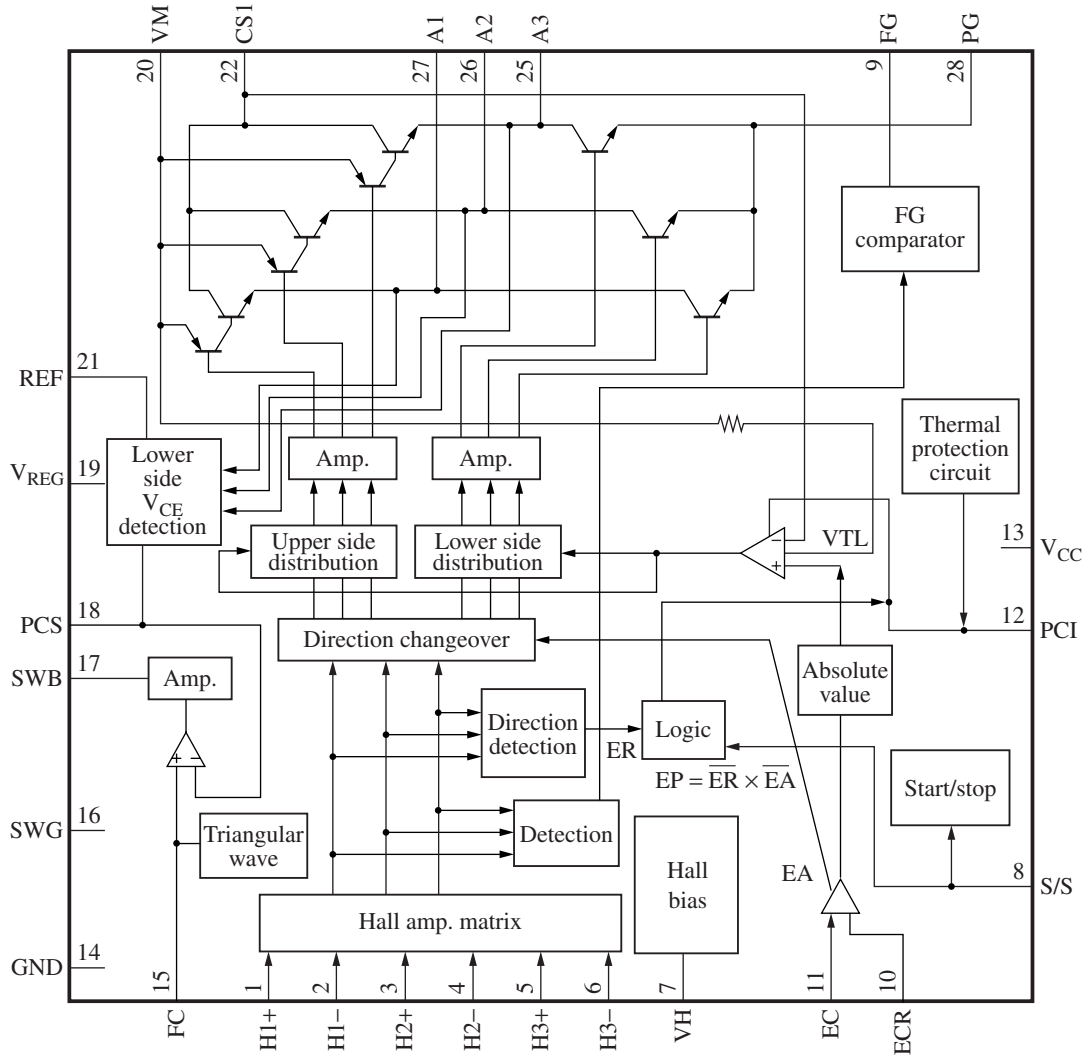

■ Pin Descriptions

Pin No.	Symbol	Description	Pin No.	Symbol	Description
1	H1+	Hall element-1 positive input pin	11	EC	Torque command input pin
2	H1-	Hall element-1 negative input pin	12	PCI	Current feedback phase compensation pin
3	H2+	Hall element-2 positive input pin	13	V <sub>CC</sub>	Supply voltage pin
4	H2-	Hall element-2 negative input pin	14	SG	Signal GND pin
5	H3+	Hall element-3 positive input pin	15	FC	Triangular wave oscillation pin
6	H3-	Hall element-3 negative input pin	16	SWG	SW-REG system GND pin
7	VH	Hall bias pin	17	SWB	SW-REG driving pin
8	SS	Start/stop changeover pin	18	PCS	SW-REG system phase compensation pin
9	FG	FG signal output pin	19	V <sub>REG</sub>	Fixed power supply pin
10	ECR	Torque command reference input pin	20	VM	Motor supply voltage pin

### ■ Pin Descriptions (continued)

Pin No.	Symbol	Description	Pin No.	Symbol	Description
21	REF	SW-REG reference setting pin	25	A3	Drive output 3
22	CS1	Current det. pin 1	26	A2	Drive output 2
23	N.C.	N.C.	27	A1	Drive output 1
24	N.C.	N.C.	28	PG	Power GND pin

### ■ Absolute Maximum Ratings

Parameter	Symbol	Rating	Unit
Supply voltage	$V_{CC}$	7.0	V
	$V_M$	14.4	
	$V_{REG}$		
Control signal input voltage *4	$V_{(n)}$	0 to $V_{CC}$	V
Supply current	$I_{CC}$	30	mA
Output current *3	$I_{O(n)}$	$\pm 1$ 200	mA
Hall bias current	$I_{HB}$	50	mA
Power dissipation *2	$P_D$	667	mW
Operating ambient temperature *1	$T_{opr}$	-20 to +70	°C
Storage temperature *1	$T_{stg}$	-55 to +150	°C

Note) Do not apply external currents or voltages to any pins not specifically mentioned.

For circuit currents, '+' denotes current flowing into the IC, and '-' denotes current flowing out of the IC.

\*1: Except for the operating ambient temperature and storage temperature, all ratings are for  $T_a = 25^\circ\text{C}$ .

\*2: For  $70^\circ\text{C}$  and IC alone.

\*3: n = 22, 25, 26, 27, 28

\*4: n = 1, 2, 3, 4, 5, 6, 8, 10, 11

### ■ Recommended Operating Range

Parameter	Symbol	Range	Unit
Supply voltage	$V_{CC}$	4.25 to 5.5	V
	$V_M$	4.5 to 14	
	$V_{REG}$		

### ■ Electrical Characteristics at $T_a = 25^\circ\text{C}$

Parameter	Symbol	Conditions	Min	Typ	Max	Unit
Overall						
Circuit current 1	$I_{CC1}$	$V_{CC} = 5$ V in power save mode	—	0	0.1	mA
Circuit current 2	$I_{CC2}$	$V_{CC} = 5$ V, $I_O = 0$ mA	—	8	16	mA
Start/stop						
Start voltage	$V_{START}$	Voltage with which a circuit operates at $V_{CC} = 5$ V and $L \rightarrow H$	3.5	—	—	V
Stop voltage	$V_{STOP}$	Voltage with which a circuit becomes off at $V_{CC} = 5$ V and $H \rightarrow L$	—	—	1.0	V

**■ Electrical Characteristics at  $T_a = 25^\circ\text{C}$  (continued)**

Parameter	Symbol	Conditions	Min	Typ	Max	Unit
<b>Hall bias</b>						
Hall bias voltage	$V_{HB}$	$V_{CC} = 5\text{ V}$ , $I_{HB} = 20\text{ mA}$	0.7	1.2	1.6	V
<b>Hall amplifier</b>						
Input bias current	$I_{BH}$	$V_{CC} = 5\text{ V}$	—	1	5	$\mu\text{A}$
In-phase input voltage range	$V_{HBR}$	$V_{CC} = 5\text{ V}$	1.5	—	4.0	V
Minimum input level	$V_{INH}$	$V_{CC} = 5\text{ V}$	60	—	—	mV[p-p]
<b>Torque command</b>						
In-phase input voltage range	EC	$V_{CC} = 5\text{ V}$	1	—	3.9	V
Offset voltage	$EC_{OF}$	$V_{CC} = 5\text{ V}$	-150	0	150	mV
Dead zone	$EC_{DZ}$	$V_{CC} = 5\text{ V}$	50	100	150	mV
Input current	$EC_{IN}$	$V_{CC} = 5\text{ V}$ , $EC = ECR = 2.5\text{ V}$	-5	-1	—	$\mu\text{A}$
Input/output gain	$A_{CS}$	$V_{DD} = 5\text{ V}$ , $R_{CS} = 0.5\ \Omega$	0.31	0.41	0.51	A/V
<b>Output</b>						
High-level output saturation voltage	$V_{OH}$	$V_{CC} = 5\text{ V}$ , $I_O = -300\text{ mA}$	—	0.9	1.6	V
Low-level output saturation voltage	$V_{OL}$	$V_{CC} = 5\text{ V}$ , $I_O = 300\text{ mA}$	—	0.2	0.6	V
Torque limit current	$I_{TL}$	$V_{CC} = 5\text{ V}$ , $R_{CS} = 0.5\ \Omega$	390	530	670	mA
<b>FG</b>						
FG output high-level	$FG_H$	$V_{CC} = 5\text{ V}$ , $I_{FG} = -0.01\text{ mA}$	3.0	—	$V_{CC}$	V
FG output low-level	$FG_L$	$V_{CC} = 5\text{ V}$ , $I_{FG} = 0.01\text{ mA}$	—	—	0.5	V
In-phase input voltage range	$V_{FGR}$	$V_{CC} = 5\text{ V}$ , Input D-range at H2+, H2-	1.5	—	3.0	V
FG hysteresis width	$H_{FG}$	$V_{CC} = 5\text{ V}$	1	10	20	mV
<b>Triangular wave oscillation circuit</b>						
Charging current	$I_{CH}$	$V_{CC} = 5\text{ V}$ , $FC = 0.5\text{ V}$	-100	-50	-25	$\mu\text{A}$
Discharging current	$I_{DCH}$	$V_{CC} = 5\text{ V}$ , $FC = 2.5\text{ V}$	25	50	100	$\mu\text{A}$
<b>Lower side voltage detection circuit</b>						
Input to output gain	$G_{VI}$	$V_{CC} = 5\text{ V}$	5	10	20	times
<b>SW-REG driving circuit</b>						
PNP driving current	$I_{SWB}$	$V_{CC} = 5\text{ V}$	10	50	—	mA

**• Design reference data**

Note) The characteristics listed below are theoretical values based on the IC design and are not guaranteed.

Parameter	Symbol	Conditions	Min	Typ	Max	Unit
<b>Thermal protection</b>						
Thermal protection operating temperature	$T_{SDON}$	$V_{CC} = 5\text{ V}$ , $\Delta EC = 100\text{ mV}$	—	170	—	$^\circ\text{C}$
Thermal protection hysteresis width	$\Delta T_{SD}$	$V_{CC} = 5\text{ V}$ , $\Delta EC = 100\text{ mV}$	—	45	—	$^\circ\text{C}$

■ Usage Notes

Prevent this IC from being line-to-ground fault. (To be concrete, do not short-circuit any of pins A1 (pin 27), A2 (pin 26) and A3 (pin 25) to  $V_{REG}$  pin (pin 19) or VM pin (pin 20).)

■ Application Notes

- $P_D - T_a$  curves of HSOP042-P-0400

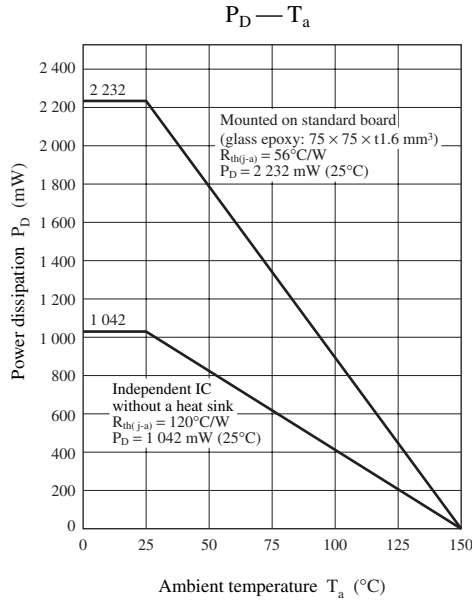

- Phase conditions between Hall input and output current

Phase of Hall pin			
	H1+	H2+	H3+
A	H	M	L
B	H	L	M
C	M	L	H
D	L	M	H
E	L	H	M
F	M	H	L

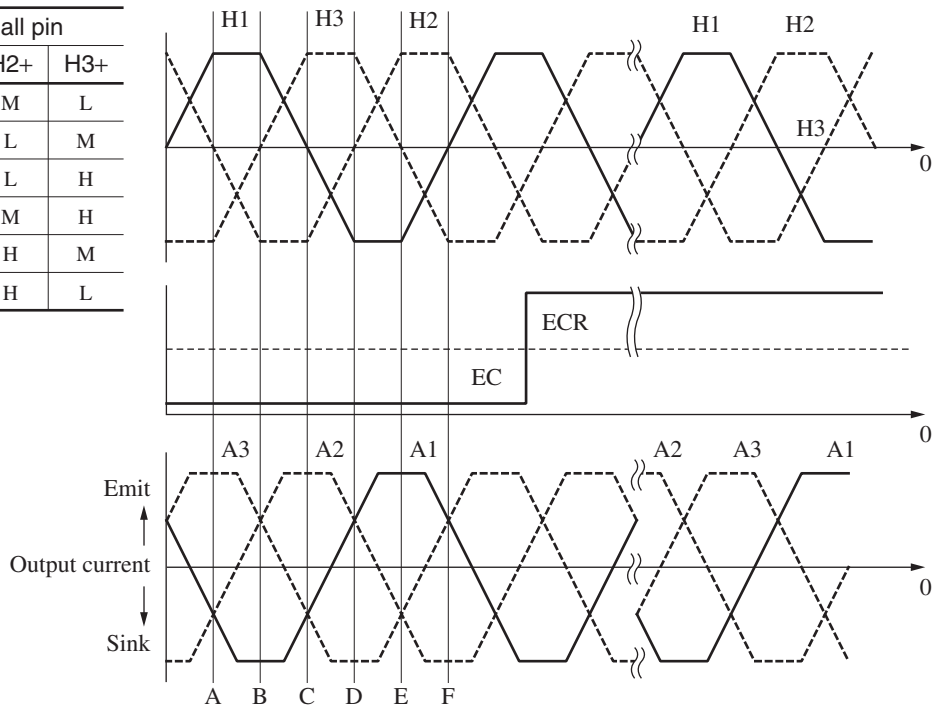

■ Application Circuit Example

