

# AN1432NT

## Variable output, low voltage operation shunt regulator

### ■ Overview

The AN1432NT is a low voltage operation and positive voltage variable output type shunt regulator. Since the output voltage is adjustable from approximately 1.275 V to 14 V, it is suitable for a power supply of small-sized 3 V-system portable equipment.

### ■ Features

- High accuracy reference voltage: 1.275 V (allowance:  $\pm 2\%$ )
- Low voltage operation: 1.275 V to 14 V

### ■ Applications

- Office automation equipment and other small-sized portable equipment

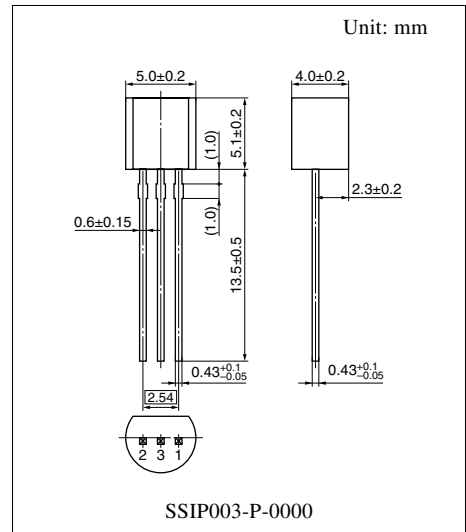

Note) The value of reference voltage and the package differ from AN1432MS.

### ■ Block Diagram

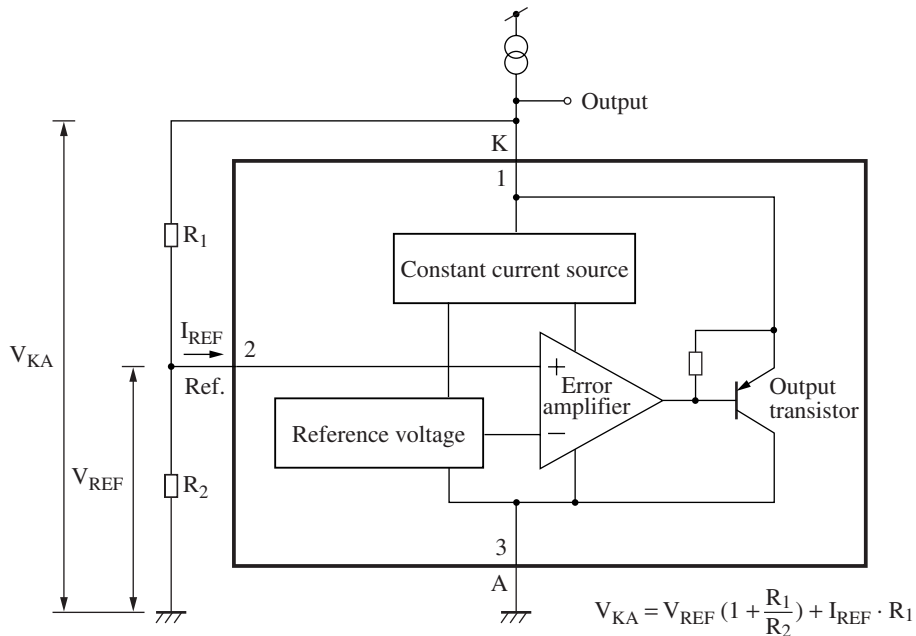

### ■ Pin Descriptions

Pin No.	Description	
1	K: Cathode	The pin for the combined use of the power source current supply of IC and the constant voltage output as the shunt regulator. An excessive current supplied to this pin is bypassed to the anode pin through the output transistor.
2	Reference	The reference voltage (1.275 V typical) pin. Although the impedance is high under the normal using conditions, be careful that the impedance drops and current flows into the IC inside if a current or voltage is forced to apply from the outside.
3	Anode	The constant voltage reference pin of the shunt regulator, and the current from the cathode and reference flows out. Usually grounded.

### ■ Absolute Maximum Ratings

Parameter	Symbol	Rating	Unit
Supply voltage	$V_K$	14.4	V
Reference voltage	$V_{REF}$	7	V
Supply current	$I_K$	20	mA
Reference current	$I_{REF}$	50	$\mu$ A
Cathode - anode reverse current	$-I_{KA}$	-10	mA
Cathode - reference reverse current	$-I_{KR}$	-10	mA
Power dissipation *2	$P_D$	340	mW
Operating ambient temperature *1	$T_{opr}$	-30 to +85	$^{\circ}$ C
Storage temperature *1	$T_{stg}$	-55 to +150	$^{\circ}$ C

Note) 1. Do not apply external currents or voltages to any pins not specifically mentioned.

For circuit currents, '+' denotes current flowing into the IC and '-' denotes current flowing out of the IC.

2. \*1: Except for the power dissipation, operating ambient temperature and storage temperature, all ratings are for  $T_a = 25^{\circ}$ C.

\*2: The value at  $T_a = 85^{\circ}$ C.

### ■ Recommended Operating Range

Parameter	Symbol	Range	Unit
Supply voltage	$V_{CC}$	$V_{REF}$ to 14	V

Note) The value of reference voltage differs from AN1432MS (surface mounting package).

### ■ Electrical Characteristics at $T_a = 25^\circ\text{C}$

Parameter	Symbol	Conditions	Min	Typ	Max	Unit
Reference voltage	$V_{\text{REF}}$	$V_{\text{KA}} = V_{\text{REF}}, I_{\text{K}} = 10 \text{ mA}$	1.249	1.275	1.30	V
Reference voltage fluctuation 1	$\Delta V_{\text{REF}} / \Delta V_{\text{KA}}$	$ V_{\text{REF}}  \leq V_{\text{KA}} \leq 5 \text{ V},$ $I_{\text{K}} = 10 \text{ mA}$	—	1.9	3.5	mV/V
Reference voltage fluctuation 2	$\Delta V_{\text{REF}} / \Delta V_{\text{KA}}$	$5 \text{ V} \leq V_{\text{KA}} \leq 15 \text{ V},$ $I_{\text{K}} = 10 \text{ mA}$	—	1.0	2.0	mV/V
Reference input current	$I_{\text{REF}}$	$R_{\text{I}} = 10 \text{ k}\Omega, I_{\text{K}} = 10 \text{ mA}$	—	2.5	4.4	$\mu\text{A}$
Minimum cathode current	$I_{\text{K min}}$	$V_{\text{KA}} = V_{\text{REF}}$	—	290	350	$\mu\text{A}$
Off time cathode current	$I_{\text{K OFF}}$	$V_{\text{KA}} = 15 \text{ V}, V_{\text{REF}} = 0 \text{ V}$	—	—	1.0	$\mu\text{A}$
Dynamic impedance	$ Z_{\text{KA}} $	$V_{\text{KA}} = V_{\text{REF}}, f \leq 1 \text{ kHz},$ $I_{\text{K}} = 1 \text{ mA to } 10 \text{ mA}$	—	0.1	0.5	$\Omega$

### • Design reference data

Note) The characteristics listed below are theoretical values based on the IC design and are not guaranteed.

Parameter	Symbol	Conditions	Reference value	Unit
Reference voltage change with temperature	$\Delta V_{\text{REF}} / \Delta T_a$	$V_{\text{KA}} = V_{\text{REF}}, I_{\text{KA}} = 10 \text{ mA}$ $0^\circ\text{C} \leq T_a \leq +70^\circ\text{C}$	3	mV
Reference input current change with temperature	$\Delta I_{\text{REF}} / \Delta T_a$	$R_{\text{I}} = 10 \text{ k}\Omega, I_{\text{K}} = 10 \text{ mA}$ $0^\circ\text{C} \leq T_a \leq +70^\circ\text{C}$	0.4	$\mu\text{A}$

### ■ Application Notes

#### 1. $P_D - T_a$ curve of SSIP003-P-0000

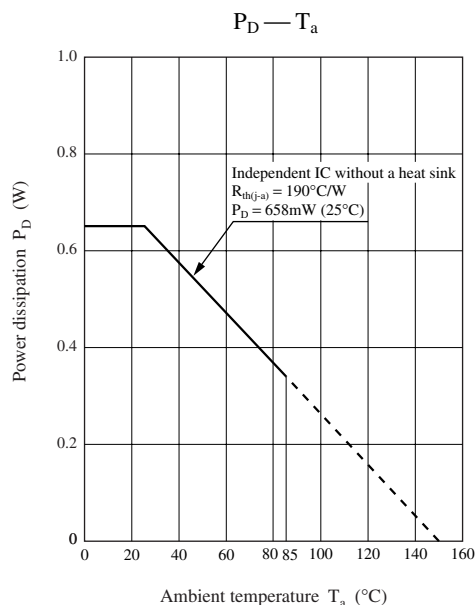

■ Application Notes (continued)

2. Main Characteristics

$V_{REF1}$  temperature characteristic

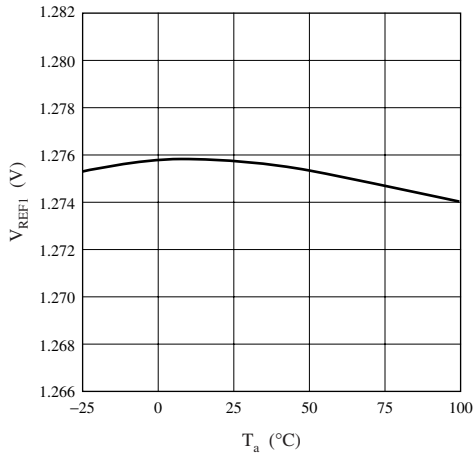

$I_{REF}$  temperature characteristic

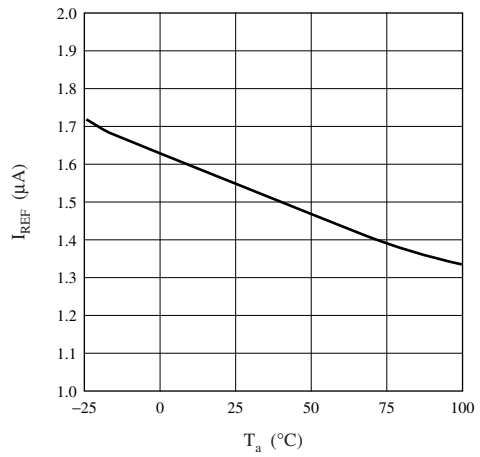

$\Delta V_{REF}$  temperature characteristic

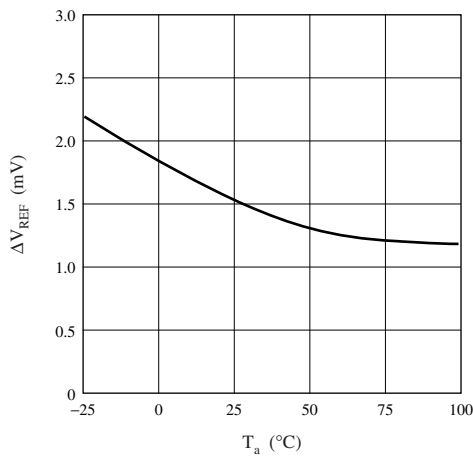

$I_{K OFF}$  temperature characteristic

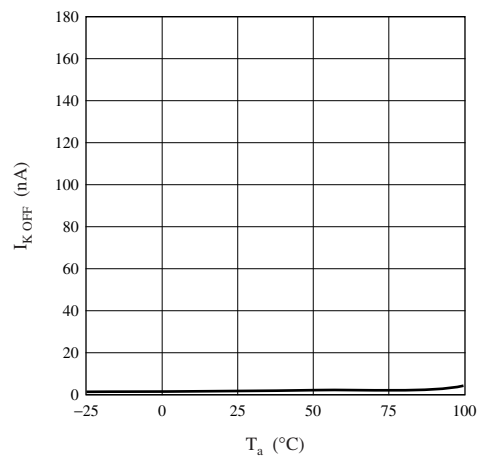

$Z_{KA}$  temperature characteristic

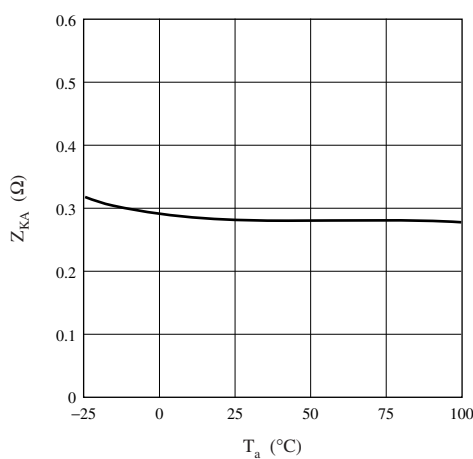

■ Application Notes (continued)

2. Main Characteristics (continued)

Gain — phase characteristics

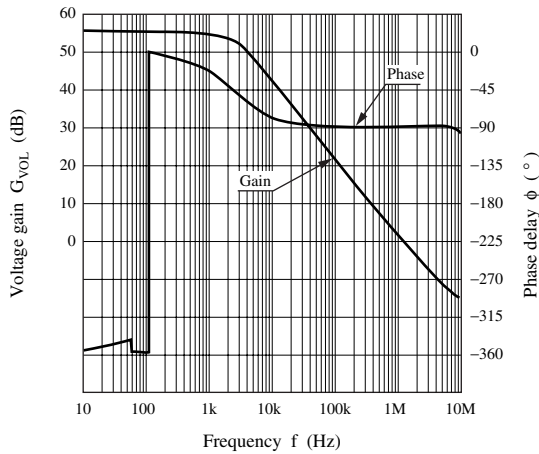

Gain — phase characteristics measurement circuit

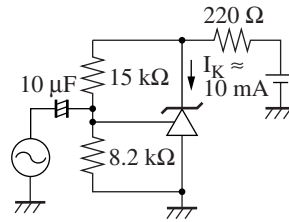

Ripple rejection ratio

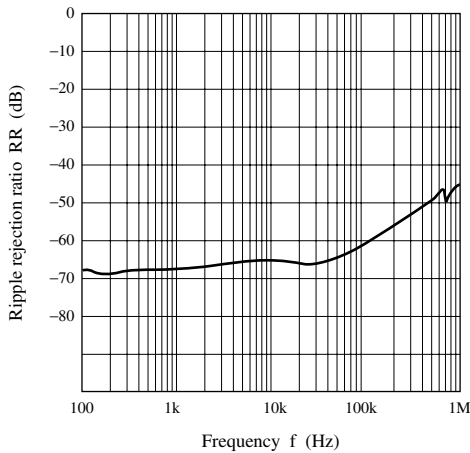

Ripple rejection ratio measurement circuit

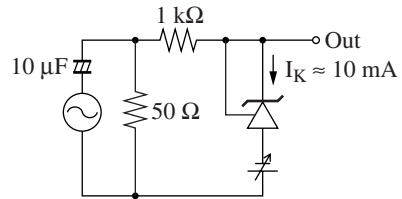

■ Application Circuit Example

This circuit amplifies the error voltage of the secondary side output voltage in the insulation type switching power supply, then transfers it to the primary side via a photocoupler.

Replaceable with the conventional products (AN1431M, AN1431T).

